

S M A R T E N E R G Y L I G H T S U P T H E G R E E N E A R T H

aloe pro

USER MANUAL



ALOE PRO-M5
ALOE -MB5

ALOE PRO-M10
ALOE -MB10

ALOE PRO-M15
ALOE -MB15

ALOE PRO-M20
ALOE -MB20

ALOE PRO-M25
ALOE -MB25

ALOE PRO-M30
ALOE -MB30



iPotisEdge Co., Ltd

Revision History

Revision history depicts the changes that were implemented in the user manual. The most current publication contains all the changes made in the previous in the versions.

Issue REV . 1 (2023-08-07)	This version is the first official release.
REV . 2 (2024-03-10)	Battery parallel (signal line) connection is added. Definition of PCS interface is changed.
REV . 3 (2024-06-07)	Three-phase AC Output Mode is added. ALOE PRO-M5 is added.
REV . 4 (2024-08-07)	APP user interface update. Ground wire, battery power wire, battery signal wire converted into finished product line for shipment. Wall mounted installation method of inverter.
REV . 5 (2024-10-16)	Update Working and Storage temperatures.
REV . 6 (2024-10-23)	Add protection switch to PDU.
REV . 7 (2025-07-18)	ALOE PRO-M25 ALOE PRO-M30 is added.

Copyright Statement

This document and the information contained herein are the property of iPotisEdge Co., Ltd. No part of this document may be reproduced or disclosed in any form or by any means to third parties or organizations or individuals without the prior written consent of iPotisEdge Co., Ltd.

Trademark Authorization

Trademarks used in this manual are owned by iPotisEdge Co., Ltd. All other trademarks or registered trademarks mentioned in this manual are the property of their respective owners.

Statement

The products, services or features to be provided hereunder shall be subject to the commercial contracts and terms of iPotisEdge Co., Ltd.

All or some of the products, services, or features described in this document may not be within the scope of supply.

Unless otherwise agreed in the contract, iPotisEdge Co., Ltd. does not make any representations or warranties, express or implied, relating the contents of this document.

This document may be updated from time to time due to product upgrading or other reasons.

Unless otherwise agreed, this document is intended as a guide to use only, and all the statements, information and recommendations in this document do not constitute any express or implied warranties.

Overview

This manual elaborates on the product profile, application scenarios, installation and commissioning, system maintenance and technical specifications of energy storage systems of ALOE PRO-M5, ALOE PRO-M10, ALOE PRO-M15, ALOE PRO-M20, ALOE PRO-M25, ALOE PRO-M30, and battery packs of ALOE-MB5, PDU ALOE PRO-MC5, ALOE-MB5, ALOE-MB10, ALOE-MB15, ALOE-MB20, ALOE-MB25, ALOE-MB30.

Intended Readers

This document is intended for:

- Sales Engineers
- System Engineers
- Technical Support Engineers
- End Users (Users are prohibited from the operations specified in the manual that must be done by licensed technicians.)

Meaning of Symbols

In order to ensure personal and property safety during installation and better user experience, this manual highlights the meaning of the industry-standard symbols.

This manual contains the following types of warnings. Please read carefully before installation.

Danger

If the instructions are not followed, death or severe injury may occur. It indicates high risk.

Warning

If the instructions are not followed, death or severe injury may occur. It indicates moderate risk.

Caution

If the instructions are not followed, minor or moderate injury may occur. It indicates low risk.

Instruction

Instruction is complementary to the key information of the manual.

It has nothing to do with personal injury, equipment damage, and environment damage.

Meaning of Warning Signs



Caution! Risk of electric shock



Keep away from flammable materials



Danger



Do not short circuit the battery



Be careful of fire



Do not install or disassemble by non-professionals



Hot surface



Install the product out of the reach of children



After power failure, there is a delay in discharging the components.
Please wait for 10 minutes until the equipment is completely discharged.



Do not throw away this product, and it shall be sent to the designated recycling place.



Do not dispose of this product with residential waste.



Recyclable



Read the instructions carefully before installation and use



CE certification

Definition of Abbreviation

Abbreviation	Full Name	Abbreviation	Full Name
FPC	Flexible Printed Circuit	SOC	State Of Charge
BMS	Battery Management System	BM	Battery Module
BMU	Battery Management Unit	PCS	Power Conversion System
BOL	Begin Of Life	EOL	End Of Life
Bus-bar	Current Connection Between Cells	OCV	Open Circuit Voltage
CAN	Controller Area Network	S/G	Switch Gear

CONTENT

1 Safety	01
1.1 Personal Safety.....	03
1.2 Electrical Safety.....	05
1.3 Battery Safety.....	07
1.4 Environmental Requirements.....	09
1.5 Mechanical Safety.....	11
2 Products	14
2.1 Product Commitment.....	14
2.2 Product Features.....	14
2.3 Working Mode.....	16
2.4 Appearance Description.....	20
2.5 System UI Logic Description.....	23
2.6 Product Specifications.....	24
3 Packaging, Transportation and Storage	26
3.1 Items Contained in the Box.....	26
3.2 Transportation Requirements.....	27
3.3 Storage Requirements.....	29
4 Installation Preparation	31
4.1 Installation Tools.....	31
4.2 Installation Protection.....	31
4.3 Safe Installation and Operation.....	32
4.4 Installation Location.....	34
5 System Installation	35
5.1 Carrying and Unpacking the Product.....	35
5.2 Base Fixing.....	36
5.3 Stacking and Fixing.....	37
6 Electrical Installation	40
6.1 Grounding Cable Connection of PCS and Battery.....	41
6.2 Battery Network Cables Connection.....	41
6.3 PCS and Battery Signal Line Connection (Synchronously Connecting CT).....	42

CONTENT

6.4 PCS and Battery Power Cable Connection	43
6.5 PV-PCS Connection.....	44
6.6 Home Circuit Rewiring (GRID & EPS Connection).....	45
6.7 Battery AC IN Connection.....	49
7 Commissioning and Operation.....	50
7.1 Inspection Before Power-on.....	50
7.2 System Power-on.....	51
7.3 System Power-off.....	51
8 Parallel-connection of the System.....	52
8.1 Dial Switch Operation.....	54
8.2 Connection of Signal Line.....	56
8.3 Connection of PV.....	57
8.4 Connection of GRID & EPS.....	58
8.5 Parameter Setting for Parallel-connection.....	60
9 APP Settings.....	63
9.1 APP Download.....	63
10 System Maintenance.....	64
10.1 Routine Maintenance.....	64
10.2 Troubleshooting.....	65
10.3 Emergency Response.....	67
10.4 Battery Recycling.....	69
11 After-sales Service.....	70

1 Safety

Statement

- Please read through this manual to strictly follow the procedures and instructions of safety signs or precautions depicted on the equipment or in this manual prior to transportation, storage, installation, operation, and O&M.
- "Equipment" and "product" herein this manual refer to the products, software, components, spare parts or services related to the contracted product. "Company" means the manufacturer (producer), seller or service provider of the equipment. "User" represents the action-taker who transports, stores, installs, operates, uses or maintains the equipment.
- The terms "Danger", "Warning", "Caution" and "Notice" in this manual do not include all safety instructions that should be observed. Users must otherwise comply with relevant international, national or regional standards and industry practices.
- The company shall not be responsible for any loss caused by the violation of safety instructions on the design, production and use of the equipment.
- The equipment must be used in an environment that complies with the design specifications. Otherwise, malfunction, system fault or damaged components or parts may occur, which are not covered by the quality guarantee of the equipment.
- Running the equipment in an environment that contradicts the design specifications may lead to personal death or property loss, for which the company shall not bear any responsibility.
- All operations such as transportation, storage, installation, operation, use and maintenance shall comply with applicable laws, regulations, standards and specifications.
- It is prohibited to reverse engineer, decompile, disassemble, adapt, and implant the equipment software. It is not allowed to study the internal logic of the equipment in any means, obtain the source code of the equipment software and infringe intellectual property rights. It is not allowed to disclose the results of any equipment software performance test.

The Company shall not be liable for any of the following circumstances or the consequences:

- Equipment damage caused by force majeure, such as earthquake, flood, volcanic eruption, debris flow, lightning strike, fire, war, armed conflict, typhoon, hurricane, tornado, extreme weather, etc.;
- Failure to operate the equipment in accordance with the operating conditions specified in the product manual;
- Failure to follow the operation and safety instructions exhibited in this manual;
- Unauthorized disassembly or change of the product or the software code;
- Damage caused by not storing the product according to this manual;
- The installation and working environment does not meet the relevant international, national or regional standards;
- Install and run the product by unqualified personnel;
- Materials and tools used by the user to operate or maintain the product do not meet the requirements of local laws and regulations and related standards;
- Damage caused during transportation by a third-party freight forwarder commissioned by the user;
- Damage caused by the negligence, fault, vandalism, improper operation of the user or a third party, or by the factors that have nothing to do with the company.

1.1 Personal Safety

Danger

- Ensure that the power is off during installation. Do not install, disassemble and connect the equipment while the power is on. Power-on installation may produce electric arc, electric-spark or flame and explosion, resulting in fire or personal injury.
- When the equipment is electrified, please operate it correctly. Otherwise, fire, electric shock or explosion may occur, leading to casualties or property damage.
- It is strictly forbidden to wear conductive accessories including watches, bracelets, bangles, rings, necklaces during operation, so as to prevent electric shock.
- During operation, use special protective equipment, such as protective clothing, insulating shoes, goggles, safety helmet, and insulating gloves. Meanwhile, use dedicated insulation tools to avoid electric shock or short circuit.
- The level of insulation resistance and withstanding voltage must comply with local laws, regulations, standards and specifications.

Warning

- Do not stop equipment protection devices and pay attention to the warnings, cautions, and precautions in the manual and equipment.
- During operation, if any fault that may cause personal injury or equipment damage is found, stop the operation immediately, report the case to the person in charge, and take effective protective measures.
- Do not power on the equipment before it is installed or confirmed by professionals.
- Do not touch the power supply equipment directly or with conductors such as damp objects.
- Before touching any conductor surface or terminal, measure the voltage at the contact point to confirm that there is no risk of electric shock.
- During the operation, the casing or enclosure is hot and there is a risk of burns. Do not touch it.
- In case of fire, evacuate the building or the area where the equipment is placed and press the fire alarm bell, or report the fire. Re-entry into the area of the burning building or equipment is strictly prohibited in any case.

Requirements for Installers:

- The personnel responsible for the installation and maintenance of the equipment must have been sufficiently trained and proven the mastery of the correct operation, the safety precautions and local standards of the country/region.

Professional: a trained, experienced technician who is proficient in the principle and structure of the equipment and understands the potential sources and levels of hazards during the installation, operation and maintenance of the equipment.

Trained person: a trained, experienced technician who is aware of the potential hazards during operation and can minimize the hazards to herself/himself and others.

- Only qualified professionals or trained personnel are allowed to install, operate and maintain, remove safety facilities and overhaul equipment.
- Personnel who will perform special tasks such as electrical operation, aerial work and special equipment operation must have the relevant qualification required by the local country/region.
- Only authorized professionals are allowed to replace the equipment or parts (including software) .
- Access to the equipment is authorized to the installer or O&M operator only.

1.2 Electrical Safety

Danger

- Before making electrical connections, make sure that the equipment is not damaged. Otherwise it may cause electric shock or fire.
- Improper or incorrect operation may cause accidents such as fire or electric shock.
- During the operation, prevent foreign matters from entering the equipment. Otherwise short circuit, equipment damage, reduced load power, power failure or personal injury may occur.
- When installing the equipment, connect the protection ground (PGND) cable first. When removing the equipment, remove the PGND cable last.

Warning

- The product must be installed, operated and maintained according to the procedures in the manual. Do not violate the step-by-step procedure in the manual amid installation without authorization.
- It is necessary to obtain permission from the grid department of the country or region before grid-connection.
- Before installing and removing the power cable, disconnect the equipment itself and its front and rear switches.
- Approval from the national or regional electricity authority is required for grid connection and operation.
- Before operating the equipment, ensure that the tools used meet the requirements and are logged in book; When the operation is over, make sure there are no dropped tools in the equipment.
- Before installing the power cable, make sure that the cable label is correct and the cable terminal is insulated.
- When installing the equipment, it is necessary to select a torque tool with appropriate range to tighten the screws. When tightening with a wrench, make sure that the wrench is not skewed and the torque error does not exceed 10% of the specified value. Screws shall be fixed with torque tools and double checked with red and blue markings.
- After installation, ensure that all electrical components, protective shells, insulating sleeves and other devices are in place to avoid the risk of electric shock.
- If the equipment has multiple inputs, disconnect all inputs, and operate the equipment after it is completely powered off.
- Before maintaining the loads or power distribution devices, turn off the output switch on the power supply equipment.

 **Warning**

- During maintenance, hang a "Do not switch on" sign on the upstream and downstream switches or circuit breakers as well as a warning sign to prevent accidental connection. The equipment can be powered on only after troubleshooting is complete.
- If it is necessary to cut off the power for maintenance, take the following safety measures: Power-off > Check the electricity > Install the grounding wire > Hang the warning sign and set up the barrier.
- Non-professionals are not allowed to open the internal components of the equipment.
- Please regularly check the equipment connection terminals, ensuring that the screws are securely tightened.
- Please regularly check whether the equipment cable is damaged. It must be replaced by professionals to avoid risks.
- Do not artificially alter, damage or block the signs and nameplates on the equipment. Promptly replace the signs that have worn out.
- Do not use solvents such as water, alcohol or oil to clean the electrical components inside and outside the equipment.

1.3 Battery Safety

Danger

- Do not short circuit the positive and negative terminals of the battery, otherwise it will cause short circuit. (A short circuit in the battery can produce a high current and release a large amount of energy, causing the battery to leak, smoke, release flammable gases, suffer from thermal runaway, flame, or explode.)
- It is strictly prohibited to maintain the battery with power on, otherwise it will cause short circuit of the battery.
- It is strictly forbidden to expose the battery to high temperature or in the vicinity of heating sources, such as hot sunshine, fire source, transformer, heater, etc. (An overheating battery may cause leakage, smoke, release of flammable gases, thermal runaway, fire, or explosion.)
- Do not touch battery terminals with other metal objects, which may cause heating or electrolyte leakage.
- Please use the batteries recommended by the manufacturer through authorized channels. Incorrect use or replacement of batteries may cause fire and explosion.
- The battery is a closed system and will not release gases under normal operation. In case of extreme cases, such as burning, pinching, squeezing, lightning strike, overcharging or other severe conditions that may lead to battery thermal runaway, the battery may be damaged or abnormal chemical reaction may occur inside the battery, resulting in electrolyte leakage or onset of gases such as CO and H₂. To avoid a burnt or corroded equipment, ensure that the flammable gases are properly exhausted.
- Non-professionals are advised not to approach in case of battery accidents (the electrolyte is toxic and volatile). Please contact a professional immediately for assistance.
- When a battery leaks, professionals should wear goggles, rubber gloves, gas masks, protective clothing, and other necessary safety gear. They should promptly deenergize the equipment and remove the leaking battery. At the same time, contact a technical engineer or the after-sales department for further handling.

Warning

- Before storage, transportation and unpacking, ensure that the outer package is intact, and the battery is placed correctly according to the mark on the packing box. Do not place the battery upside down, sideways, vertically or obliquely. Stack the battery in accordance with the stacking requirements on the outer package, so as to prevent the battery from being dropped or crashed.
- Install batteries in areas far away from liquids. Do not install them in places prone to water leakage, such as air conditioning outlets, vents, outlet windows of machine room, water pipes, etc. Ensure that no liquid enters the equipment to prevent system failure or short circuit.

 **Warning**

- Tighten the fastening screws of the copper bar or cable according to the torque specified in the manual, and regularly check whether they are tightened and whether there is rust, corrosion or other anomaly. Otherwise, the false connection of screws will lead to excessive connection voltage drop, or even ignite the battery when the current is high.
- After the battery is discharged, charge them in time to avoid damage due to over-discharge.

1.4 Environmental Requirements

Danger

- The installation and operation environment shall comply with local laws and regulations and relevant international, national and regional standards for Li-ion batteries.
- Do not place or run the equipment in an environment with flammable and explosive gas or smoke.
- Do not place or run the equipment in a humid environment near the water sources and chemical industries.
- Do not place inflammable and explosive articles in the vicinity of the equipment.
- Do not put the equipment near sources of heat or fire, such as fireworks, candles, or heaters. A heating equipment may cause system failure or fire.
- Do not install the equipment in a moving environment such as ships, trains and automobiles.
- Do not install the equipment in an environment with metal conductive dust and magnetic dust.
- Do not install the equipment in an environment with direct sunlight, dust, smoke, volatile gas, corrosive gas, infrared radiation, organic solvent or salty conditions.

Warning

- The equipment shall be installed in the area far away from liquid. It is strictly prohibited to install it under the water pipe, air outlet and other condensation-prone places.
- Do not install the equipment under the air conditioning port, ventilation port, cable outlet and other places vulnerable to water leakage, so as to prevent liquid from entering the equipment and causing equipment failure or short circuit.
- When the equipment is running, do not block the vent, cooling system or other objects to prevent overheat-induced damage to the equipment or fire.
- Keep the installation location out of the reach of children and far away from the working and living areas, including but not limited to the following: studio, bedroom, living room, music room, kitchen, study, game room, home theater, sun room, toilet, shower room, laundry room and attic.
- Do not install in closed, unventilated places without proper fire fighting facilities or difficult for firefighters to reach.
- When the equipment is running, the equipment enclosure and fins of heatsink will overheat.
- Do not install it in a position that is easily accessible.
- Do not install, use and operate outdoor equipment and cables in bad weather such as thunder and lightning, rain, snow and gale above Grade 6. (Such installation includes but not limited to handling equipment, operating equipment and cables, plugging and unplugging signal interfaces connected to the outdoors, working at heights, outdoor installation, door opening, etc.)

 **Caution**

- If the product is to be installed in a garage, it must stay away from where the vehicles come in and out and park. It is recommended to wall-mount it higher than the vehicles' bumper to avoid accidental collision.
- Do not install it in such places susceptible to water damage as low spots. Precautionary measures must be taken for the installation at areas prone to frequent natural disasters, such as floods, debris flows, earthquakes and typhoons.
- It is strictly forbidden to install the product in the salinity-intensive environment, so as to avoid corrosion. Salinity-intensive environment refers to the area within 500m from the coast or the area with heavy sea wind blow. Areas with heavy sea wind differ in the meteorological conditions (e.g. typhoon, monsoon) or the terrain (with dams, hills).
- Please install it in a sheltered place or build a sunshade for it to avoid direct sunlight or rain.
- Please install the product in a firm land without rubber soil, soft soil and subsidence. It is strictly prohibited to install the product in low spots prone to water or snow. The water level of the installation site should be higher than the highest recorded water level of the area.
- If it is to be installed in a lush spot, in addition to vegetation clearance, it is necessary to harden the land via laying cement or gravels.
- Before installation, operation and maintenance, it is necessary to remove the water, ice and snow or other debris around and on the top of the product.
- Before installation, please ensure that the surface of the installation spot is solid enough to bear the product.
- After installation, remove the packaging materials such as cartons, plastic foam, plastics, cable ties, etc.

1.5 Mechanical Safety

Danger

When working at heights, wear safety helmet, safety belt or waist rope and fasten it to a solid structure. Do not hang on a moving and unstable object or metal objects with sharp edges and corners, so as to prevent the hook from slipping and falling.

Warning

- Do not use the tools that are defective, substandard or beyond the validity period. Use firm and reliable tools.
- Do not drill holes in the equipment. Drilling will damage the tightness, electromagnetic shielding performance, internal devices and cables of the equipment. The metal chips generated during the drilling will enter the equipment and cause a short circuit of the circuit board.

Caution

- Paint scratches during equipment transportation and installation must be repaired in time. Do not expose the scratched parts for a long time.
- Do not conduct arc welding or cutting without the written permission of the company.
- Do not install other devices on top of the equipment without the written permission of the company.
- When working in the space above the top of the equipment, take measures to protect the equipment from damage.
- Prepare complete tool kits and use them correctly.

● Notice for Drilling

- Obtain consent from the client and the contractor before drilling holes.
- Wear safety equipment such as goggles and protective gloves.
- Bypass the embedded pipes or lines that will otherwise cause short circuit or other dangers.
- Shield the equipment from drilling-induced chippings.

● Instructions for Carrying Heavy Objects

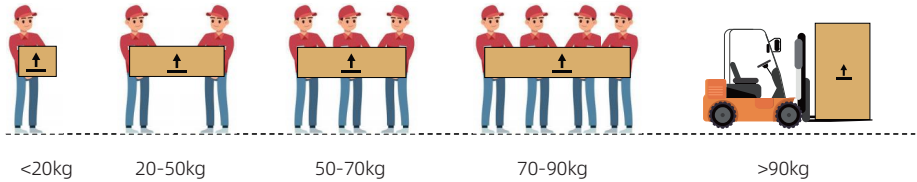

- Do not manually carry heavy objects. Otherwise the carrying persons may be crushed or suffer from sprain.
- When the heavy objects are manually co-carried, it is necessary to consider the carrying persons' height and teamworking to ensure the balanced distribution of weight.
- Please lift the heavy objects slowly, or place them on a half-waist-high workbench or a suitable place, and adjust the position of palms before lifting.
- Heavy objects must be carried with balanced and steady force. The moving speed shall be uniform and low. The ground shall be flat and stable to ensure the objects to be carried will not be crushed or dropped.
- When carrying heavy objects, pay special attention to the workbench, slope, stairs and slippery places. When carrying heavy objects through the threshold, make sure that the door is wide enough for the objects to pass through, so as to prevent bruising or scratching fingers.
- When a forklift is used, its fork must be in the middle position to prevent overturning. Before moving, please fasten the equipment to the forklift with ropes. While moving, assign dedicated personnel to take care of it.
- During transportation, fix the equipment firmly to minimize bumps and inclines.

● Notice for Use of Ladder

- Use wooden or insulated ladders when performing live-line operations at heights.
- Platform ladder with protective fence is preferred for necessary climb, while straight ladder is not recommended.
- Before using the ladder, please confirm that it is intact and its load bearing capacity meets the requirements. Do not overload it.
- Place the ladder in a stable place and have it held tightly during operation.
- When climbing the ladder, keep your body steady and your center of gravity within the ladder frame, so as to ensure safety.
- When using a herringbone ladder, the rope must be firm.
- If a straight ladder is used, its inclined angel should be 75 °, which can be measured with an angle square.

- If a straight ladder is used, place the wider feet of the ladder down or protect the bottom of the ladder from slipping.
- If a straight ladder is used, the maximum height of the feet should not exceed the fourth rung lower than the top.
- If a straight ladder is used to climb the platform, the vertical height of the ladder shall be at least 1 meter above the platform.

● Notice for Aerial Operation

- Work carried out above 2 meters from the ground amounts to aerial work, for which a supervisor must be around.
- Operators must be trained and certified before they can work at heights.
- Do not work at heights when the steel pipe is not dry or other dangerous situations may occur. After the above conditions no longer exist, the person in charge of safety and relevant technical personnel must check the involved equipment and confirm the safety before operation.
- Set a restricted area and prominent signs for working at heights to warn away irrelevant access.
- Set up guardrails and signs at the edges and openings of aerial operation to prevent falls. Do not pile up scaffolds, springboards or other sundries under the aerial work area.
- Personnel on the ground are strictly prohibited to stay or pass directly under the aerial operation area.
- Take good care of the operating instruments and tools to prevent equipment damage or personal injury caused by dropped tools.
- During aerial operation, do not throw objects from the height to the ground or vice versa.
- Transport objects by sling, hanging basket, aerial device or crane.
- Do not have two or more persons worked on the same scaffold simultaneously. If you have to, take a special protective shed to set them apart or take other protective measures. Do not stack together tools or materials on the top of a scaffold.
- After finishing the work, dismantle the scaffolds from top to bottom. Do not dismantle the upper and lower sections at the same time. When dismantling a part, ensure the other parts do not collapse.
- Do not play around or eat when working at heights.
- The personnel working at heights shall operate in strict accordance with the safety regulations, and the Company shall not be responsible for any accident caused by violation of the aerial operation regulations.

2 Product

2.1 Product Commitment

iPotisEdge promises that the products are free from defects caused by improper materials.

2.2 Product Features

The ALOE PRO-M consists of an electric control box (ALOE PRO-MC5), and a stackable battery pack (ALOE-MB5). One ALOE PRO-MC5 can be connected with 1-6 battery packs.

Intelligent interconnection:

With a n e m b e d d cloud platform, users can view the product parameters and operating status in real time through mobile phone.

Intelligent display:

On the front of the product are a display screen, a digital display window and indicator lights, which enable users to observe the system working status.

Off-grid living:

In the off- grid mode, the product can power the household loads through solar panels.

Wake-up function:

When the residential loads begin to work, the product can return from low power mode to normal operation.

Low power/Energy saving:

When the loads of the house stay idle, the product can enter a low power mode (energy saving mode) for a period of time.

Stable voltage and frequency:

The intelligent algorithm facilitates stable voltage and frequency for the residential electricity and thus guarantees the safe use of electrical equipment.

Scalable capacity:

The inverter-enabled parallel-connection of multiple systems makes it easier to scale up capacity and power, whose total output power is slightly lower than the rated power.

Push-to- start:

After closing all the air switches, the whole system can be activated by simply pushing t he power button.

Stackable pack:

By stacking the PACK on a single battery string, the power capacity can expand from 4.8kWh to 28.8kWh. One electric control box is stackable up to 6 packs.

Multiple protection:

The PACK is equipped with multiple circuit protection devices to effectively safeguard the equipment. There is no voltage output between the PACK terminals during installation, operation and maintenance, so as to fully protect the user's safety.

Battery discharge:

If the PV-generated electricity is insufficient to power the load, the system will assign the battery to deliver electricity to the load in a way that the stored battery energy will be released to the load via the inverter.

Battery charge:

Connected to the storage terminals (BAT+, BAT-) of the inverter, the battery modules are charged and store excess PV-produced and grid electricity. Alternatively, if the PV-generated electricity is continuously insufficient, the fastcharge mode can be activated to feed the grid electricity into the battery to avoid over-discharge.

Quick-connect modules :

The quick-connect design between each functioning module (PACK and PACK, PACK and electric control box) means that electrical connection of the system is completed immediately after the modules are stacked , eliminating the need of wiring.

Lightweight design:

With a single pack ≤ 49 kg and the control box ≤ 14 kg, it makes transportation and installation easier.

Easy multi-system parallel-connection:

Since a single system is composed of a hybrid inverter and batteries (1~4 packs), multiple systems can be easily parallel-connected by interfacing the communication line between the inverters. In order to keep stable system output, it is recommended that the power of each system be uniform.

Self-recovery from extended deep discharge :

When the battery has been deeply discharged for a long time and AC power is available, pressing the push-to-start button will activate the self-recovery mode from the extended deep discharge. this mode, the inverter is allowed to charge the battery with safe current.

Easy mounting:

It can be either wall mounted or floor mounted. (Accessories are provided for floor-mounted installation only. Wall-mounted installation accessories are not covered in the purchase of the product.)

2.3 Working Mode

The applicable inverter has a variety of working modes, and the end user can quickly switch the function settings through the function buttons on the display screen.

• Self-Sustaining Mode

01. Under this mode, the power consumption in priority order is Load > Battery > Grid.

The PV-generated electricity is prioritized to power local loads, and then to charge the battery. Last, the surplus electricity is fed into the grid. (This model can only be used when local laws and regulations allow).

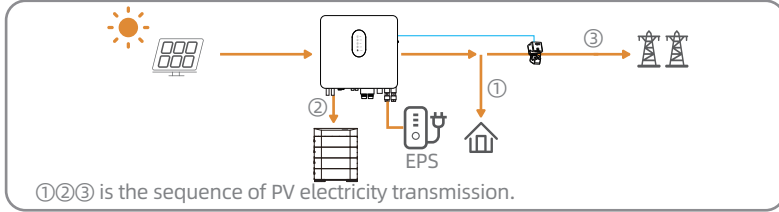

02. **Limited PV electricity input:** When the PV generation is insufficient, the electricity generated by PV is entirely transmitted to power the loads, and the gap is mitigated by the battery, followed by the grid supply.

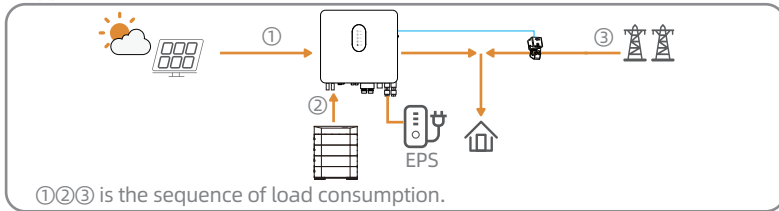

03. **No PV electricity input:** When there is no PV electricity input, the battery will be prioritized to power residential loads, followed by the grid.

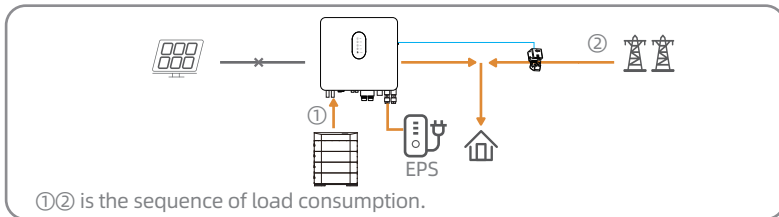

• Grid-Before-Battery Mode

01. Under this mode, the power consumption priority order is Load > Grid > Batteries.

PV power generation gives first priority to power local loads and second priority to feed back to the grid, after which the remaining electricity is used to charge batteries.

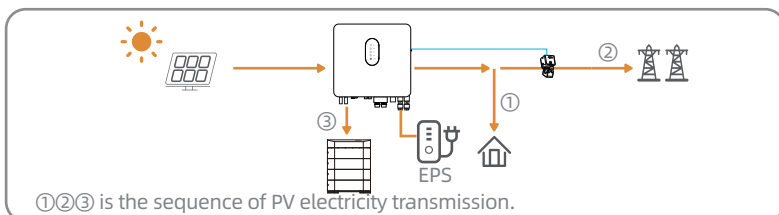

02. Limited PV generation: When the PV generation is insufficient to match the grid-feeding frequency, the battery will discharge to power residential loads.

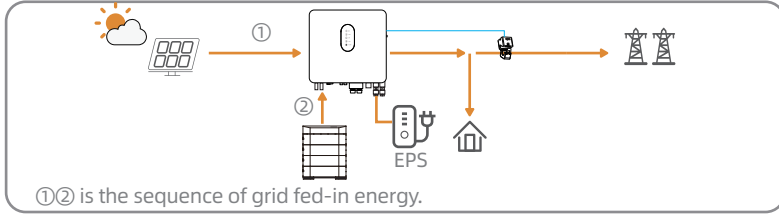

03. No PV input: When there is no PV input (such as at nights or in rainy days), the inverter will first release the battery energy for residential consumption. If the demand is not met, the grid Power will be drawn.

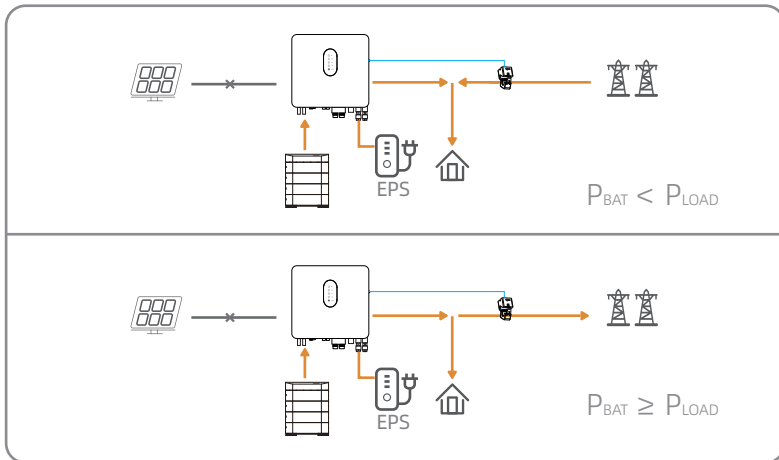

• **Time-Based Control Mode** (Non-standard function, only available to certain regions)

you can control the charging and discharging of the inverter simply by setting the following parameters as required:

- Charge and discharge frequency: one time or daily
- Begin of charge : 0~24 hours
- End of charge: 0 ~ 24 hours
- Begin of discharge : 0 ~ 24 hours
- End of discharge : 0 ~ 24 hours

You can also choose whether to allow the grid to charge the battery, which is disabled by default.

After enabling "On-grid charging function", you can set the "maximum on-grid charging power" and "on-grid charger capacity". When the battery capacity reaches the set value, the grid will stop charging the battery.

• Back-up Mode

Under this mode, the priority order of PV power consumption is Battery > Load > Grid.

This mode is designed to charge the battery quickly, while you can choose whether to charge the battery on AC.

Forbid AC Charging

Under this mode, the battery can only be charged by the PV power generation, and the charging power varies with the PV power generation.

01.Sufficient PV Power Generation: When the PV energy is sufficient, the PV first charges the battery, then discharges to the load, and last, the surplus is fed into the grid.

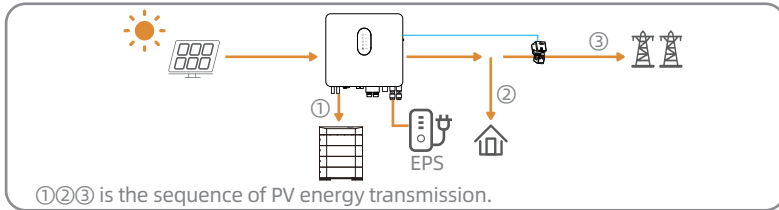

02.Limited PV Power Generation: When the PV energy is limited, the PV gives priority to battery charging, and the grid directly emits to power the loads.

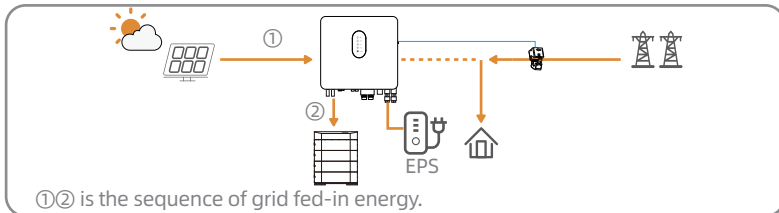

Allow AC Charging

01.Sufficient PV Power Generation: When the PV energy is sufficient, the PV first charges the battery, then electrifies the load, and last the rest is fed into the grid.

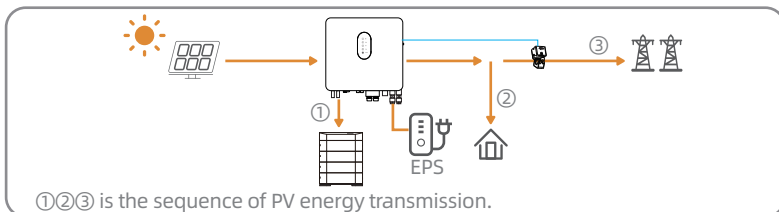

02.Limited PV Power Generation: When the PV energy is limited, PV gives priority to battery charging, and the grid directly powers the load.

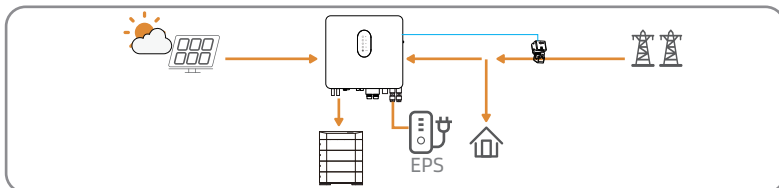

- **Off-grid mode (This mode cannot be set by the user. The system automatically switches to off-grid mode if there is a power failure)**

⚠ Instruction

When the power grid fails, the system automatically switches to off-grid mode. In off-grid mode, only critical loads are powered to ensure that important loads continue to work. In this mode, the inverter cannot operate without a battery.

01.Sufficient PV Power Generation: When the PV energy is sufficient, the PV power will first be consumed by critical loads and then charge the battery.

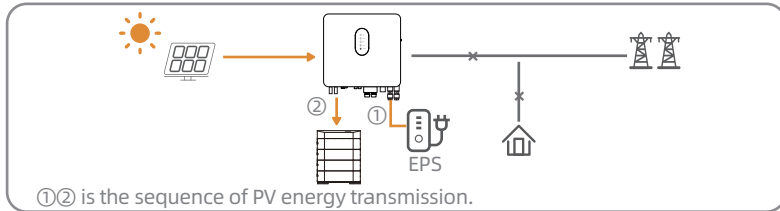

02.Limited PV Power Generation: When the PV energy is limited, emergency power supply (EPS) loads are first powered by the PV and then by batteries.

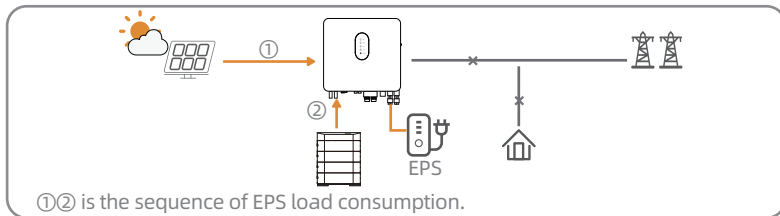

⚠ Warning

Note: Under this mode, please set the output voltage and frequency first.

If the EPS output loads are inductive or capacitive loads, it is advised to set the power of these loads within 50% of the EPS output power range to ensure system stability and reliability.

⚠ Instruction

Due to different local policies, the functions may vary in different regions. The specific functions depend on the actual products the customers receive.

2.4 Appearance Description

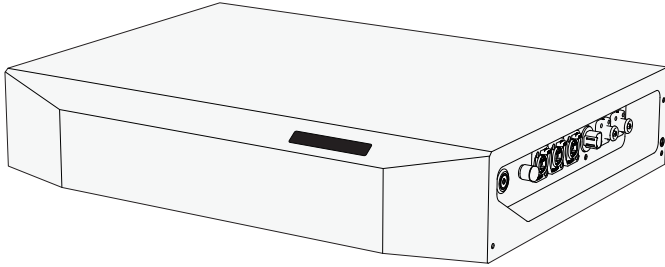

Electric control box ALOE PRO-MCS

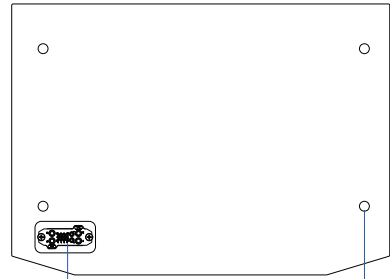
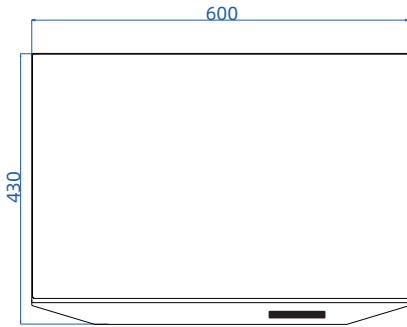

Quick-connect terminals

positioning hole

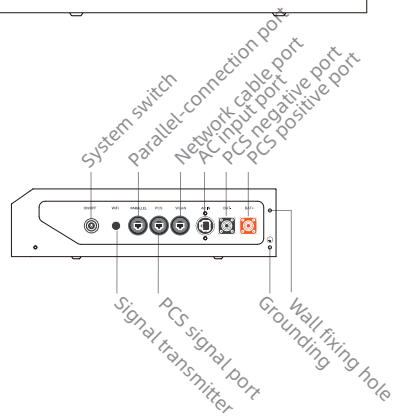
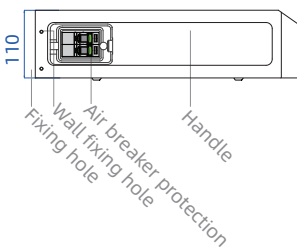
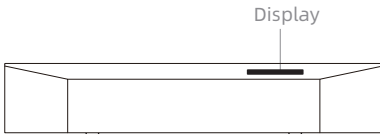

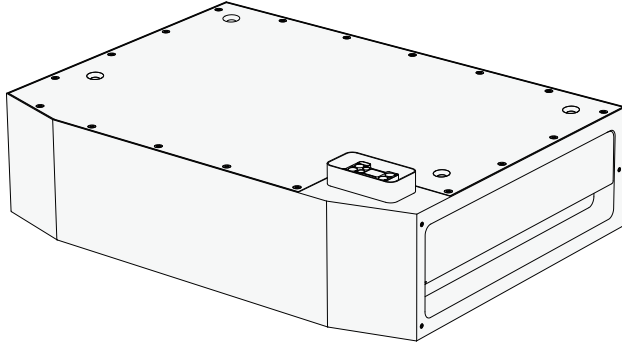

Battery pack ALOE-MB5

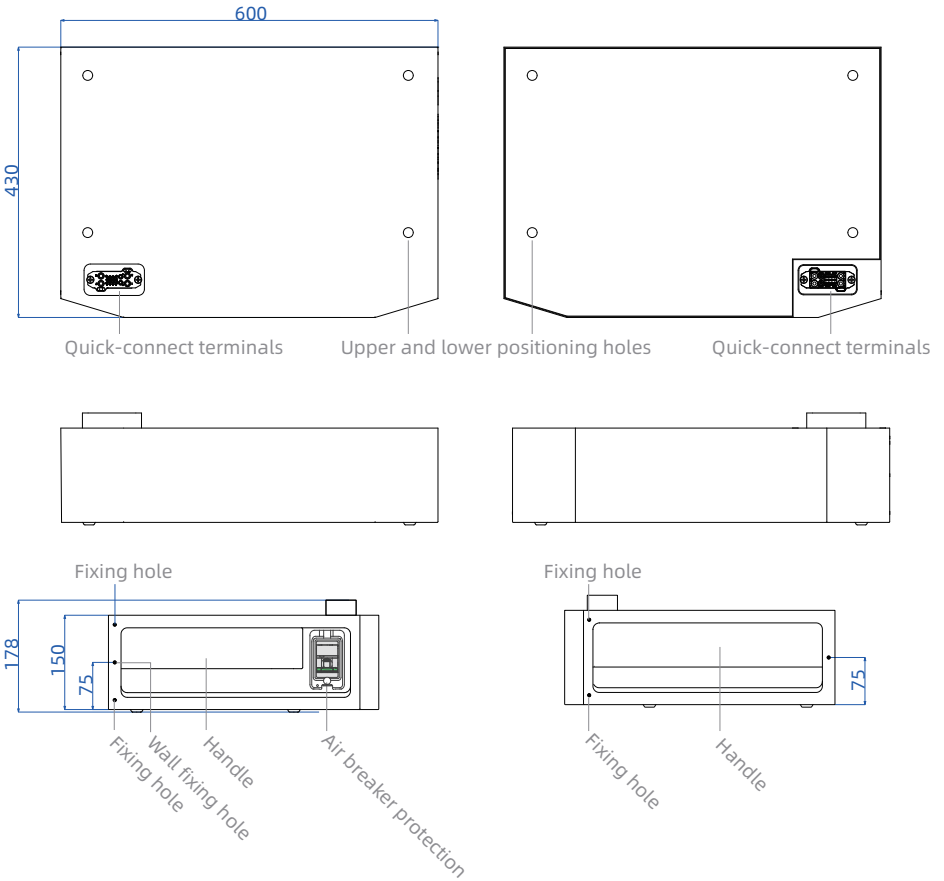

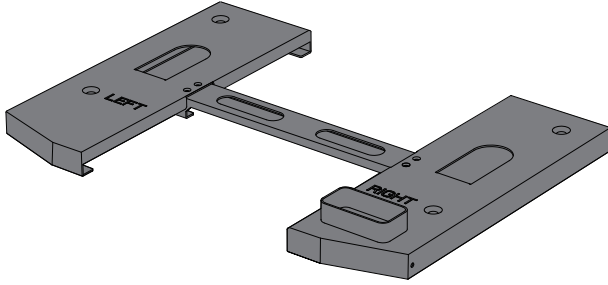

Base

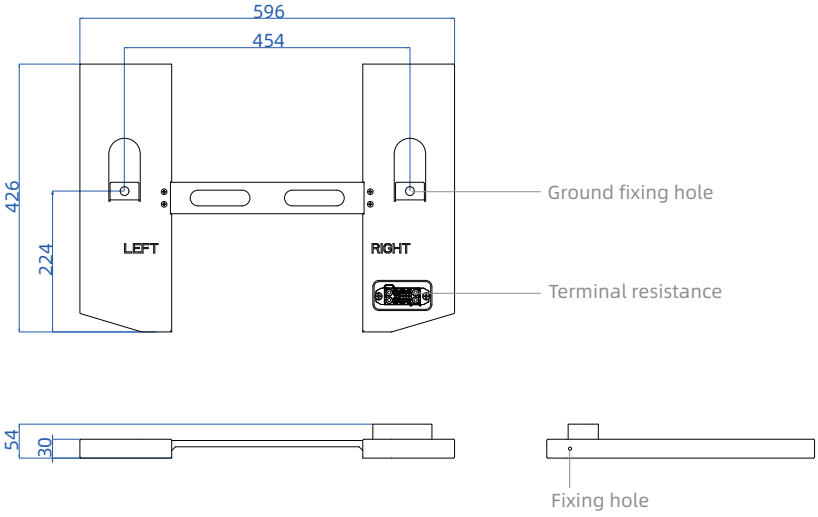

2.5 System UI Logic Description (Battery)

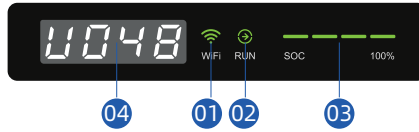

No.	Display panel	Light definition
01	WiFi	<p>WiFi status</p> <p>On: WiFi connection (Green light stays on)</p> <p>Off: WiFi not connected or faulty</p>
02	RUN	<p>System status</p> <p>Stay on: System in normal operation, discharging</p> <p>Flashing: System in normal operation, charging</p> <p>Stay on: System alarm, discharging</p> <p>Flashing: System alarm, charging</p> <p>Stay on: System fault, stop working</p> <p>Flashing: System fault, charging (triggered only when the battery is close to running out of juice)</p> <p>Off: Powered off</p>
03	SOC	<p>The remaining electricity available</p> <p>25% < SOC ≤ 100% Green light stays on</p> <p>25% < SOC ≤ 75% Green light stays on</p> <p>25% < SOC ≤ 50% Green light stays on</p> <p>SOC ≤ 25% Yellow light stays on</p> <p>Faulty</p>
04	Digital display frame	<p>Fault level</p> <p>No fault, voltage and current alternately display Voltage:48V Current:14.4A</p> <p>Alarm (reduced power, yellow light displays Ar)</p> <p>Fault (power failure, red light displays Er)</p>
		<p>High cell voltage</p> <p>Low cell voltage</p> <p>High battery voltage</p> <p>Low battery voltage</p> <p>High cell voltage difference</p> <p>High cell temperature</p> <p>Low cell temperature</p> <p>High cell temperature difference</p> <p>High charging current</p> <p>High discharge current</p> <p>High MOS temperature</p> <p>Battery pack offline (≥1 pack has minor fault. All packs going offline means serious fault.)</p> <p>Loss of communication between BMS and inverter</p> <p>Outnumbered parallel-connection</p> <p>Control circuit fuse is triggerd(only for serious fault)</p> <p>Pre-charging failure (≥1 alarm fault, signalling all packs are disconnected.)</p> <p>System short circuit/overcurrent (serious fault only)</p> <p>MOS short circuit fault (serious fault only)</p> <p>PACK air switch disconnection fault(serious fault only)</p>

2.6 Product Specification

! Instruction

The DOD(depth of discharge) of the new battery is 100%, and all the data are measured in the temperature range of 25±2°C, under the condition of 0.5P(50% of the maximum power)charge and discharge.

The rated charge and discharge current and power are affected by temperature and SOC.

Model

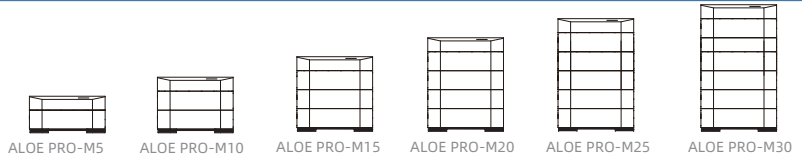

System Specification

Battery Box Quantity	1	2	3	4	5	6
Rated Capacity	4.8kWh	9.6kWh	14.4kWh	19.2kWh	24kWh	28.8kWh
Weight	59kg	104kg	149kg	194kg	239kg	284kg
Dimensions (W x D x H)	600*430*290mm	600*430*440mm	600*430*590mm	600*430*740mm	600*430*890mm	600*430*1040mm
Rated Charging/Discharging Current	50A	100A	100A	100A	100A	100A
Max. Continuous Charging/Discharging Current	60A/70A	120A/140A	120A/140A	120A/140A	120A/140A	120A/140A
Battery Type	LFP					
Nominal Voltage	48Vd.c					
Efficiency	97.3%(PV to AC); 94.3%(BAT to AC)					
DOD	100%					
Communication Port	LAN/WIFI					
Scalability	Up to 6 Units in Parallel					
Protective Class (I , II , or III)	class I					
Ingress Protection	IP65					
Altitude	< 2000m					
Working Temperature	0°C~45°C(charging), -10°C~45°C(discharging)					
Storage Temperature	0°C to 30°C					
Relative Humidity	5%~95%, RH					
Installation Mode	Floor					
Working Environment	indoors, outdoors					
Certifications	IEC/EN62619、IEC/EN60730、IEC/EN61000、IEC/EN300328, ICASA、NRS 097、UN38.3、UN3480					

Model



System Specification

Battery Box Quantity	1	2	3	4	5	6
Rated Capacity	4.8kWh	9.6kWh	14.4kWh	19.2kWh	24kWh	28.8kWh
Weight	45kg	90kg	135kg	180kg	225kg	270kg
Dimensions (W x D x H)	600*430*178mm	600*430*328mm	600*430*478mm	600*430*628mm	600*430*778mm	600*430*928mm
Rated Charging/Discharging Current	50A	100A	100A	100A	100A	100A
Max. Continuous Charging/Discharging Current	60A/70A	120A/140A	120A/140A	120A/140A	120A/140A	120A/140A
Battery Type	LFP					
Nominal Voltage	48Vd.c					
Efficiency	97.3%(PV to AC); 94.3%(BAT to AC)					
DOD	100%					
Communication Port	LAN/WIFI					
Protective Class (I , II , or III)	class I					
Ingress Protection	IP65					
Altitude	< 2000m					
Working Temperature	0°C~45°C(charging), -10°C~45°C(discharging)					
Storage Temperature	0°C to 30°C					
Relative Humidity	5%~95%, RH					
Certifications	IEC/EN62619、IEC/EN60730、IEC/EN61000、IEC/EN300328, ICASA、NRS 097、UN38.3、UN3480					

⚠ Instruction

This equipment needs to be used with inverters, and it is recommended to use the ancillary inverters provided by the company. If you have to use other inverters, please contact the supplier in advance to make adaptations.

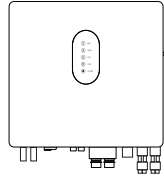

Model

Single-phase ESS Inverter

PV Input

Max. PV Input Power	9000 W
Max. PV Voltage	550 Vd.c
Quantity of MPPT	2
Number of Strings per MPPT	1
Max. input current	15 A
Max. Short Circuit Current	20 A

OUTPUT Grid

Rated AC output power	6000 W
Rated AC output voltage	230 Va.c, single phase
Rated grid frequency	50 Hz/60 Hz
Max. AC output current	27.2 A
Efficiency	99%
THDI	< 3% (Rated Power)

OUTPUT Back up

Rated output power	6000 W
Max. Output Current	26 A
Rated output voltage	230 Va.c, single phase
Rated output frequency	50 Hz/60 Hz
THDV	< 3% @ 100% R Load

Efficiency

Max. efficiency (PV to AC)	97.3%
Max. efficiency (BAT to AC)	94.3%
Euro. Efficiency (PV-AC)	96.8%

GENERAL DATA

Dimensions (W*D*H)	515*175*487mm
Weight	25kg

Certifications

IEC62109-1&2, IEC61000-6-1/2/3/4, G99/1-8: 2021
 RD 1699:2011, RD 661:2007, RD 647:2020, RD 413:2014
 UNE 217002:2020, C10&11 2021, AS4777.2

3 Packaging, Transportation and Storage

Before product acceptance, please check the following in detail:

- Check the outer package for visible damage, such as deformation, holes, cracks, or other signs of possible internal damage. If there is any damage, do not open the package and contact the distributor.
- Check if the inverter model is correct. If there is any discrepancy, do not open the package and contact the distributor.
- Check whether the type and quantity of delivered parts are correct and whether the appearance is damaged. If damaged, contact the distributor.

3.1 Items Contained in the Box

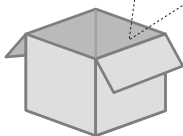
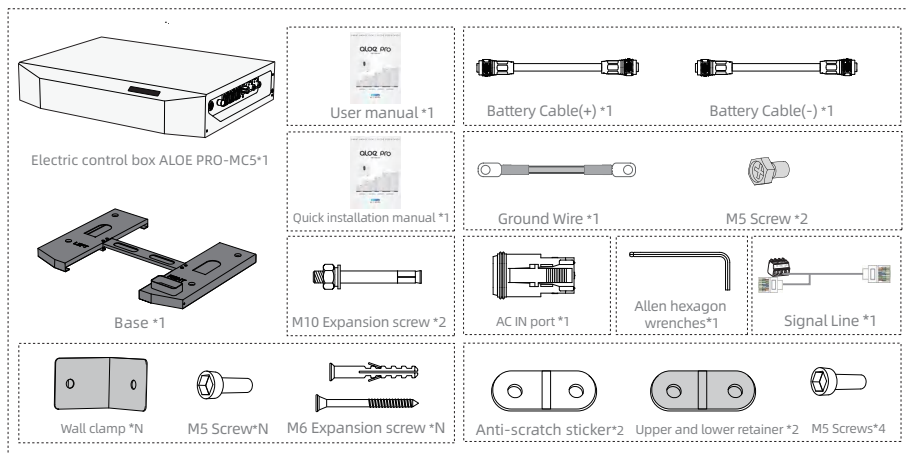

Instruction: N means the tool is not necessarily provided.
N can be 0.
It is only distributed in specific models.

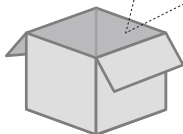
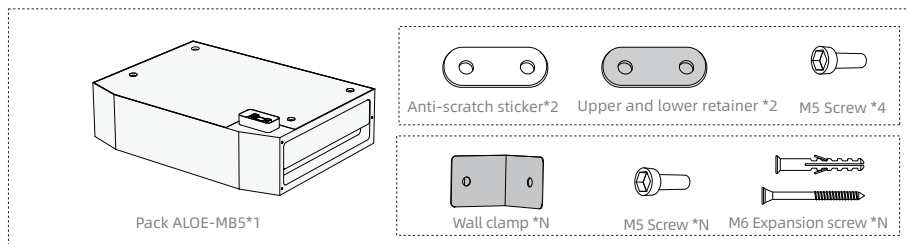

Instruction: N means the tool is not necessarily provided.
N can be 0.
It is only distributed in specific models.

Note: Accessories may differ depending on product version. Wire harness are replaced with terminals in some versions, which need to be made on the site.

3.2 Transportation Requirements

- Do not violently load and unload the product, otherwise it may cause short circuit, damage (leakage, rupture, etc.), fire or explosion.
- Do not handle the battery through its terminals, bolts or cables to avoid damaging the battery. The battery shall be handled in required direction. Do not invert, tilt, drop, or mechanically crash the battery. Exposure to rain or snow and dropping into water are not allowed.
- Before unpacking, storage, and transportation, ensure that the outer packaging is intact, and the battery is placed correctly according to the label on the packaging box. Do not place it upside down, sideways, vertically or tilt it. When stacking, it shall meet the stacking requirements set on the outer packaging, so as to avoid any damage or scratch. The batteries pass UN 38.3 (UN 38.3: Section 38.3 of the sixth Revised Edition of the Recommendations on the Transport of Dangerous GOODS: Manual of Tests and Criteria UNK2) and SN/T 0370.2-2009.
- This product is included in Class 9 dangerous goods according to the Part 2 Performance Inspection of Rules for Inspection on Packaging of Dangerous Goods for Export.
- Transportation supplier must be qualified to transport dangerous goods. Do not transport the product by open vehicles.
- Batteries can be delivered to the site directly via the road or sea transportation.
- Comply with the international rules for the transport of dangerous goods and meet the requirements of the transport regulatory authorities in the country of origin, transit and destination.
- Sea transportation or roads with better conditions is the ideal option. Do not transport the product by railway or air. Minimize possible bumps or tilts during transportation.
- Shipping shall comply with the shipping requirements of the International Maritime Dangerous Goods Code (IMDG Code).
- ADR or JT/T 617 shall be met for land transport.
- Before transportation, it is necessary to confirm that the battery package is intact, and there is no odor, leakage, smoke, or flame. Otherwise transport shall be cancelled.
- The packing box for transportation must be firm, and it shall be handled with care during loading, unloading and transportation, and moisture-proof measures shall be taken.
- Handle the battery with care. Do not touch the battery. Ensure personal safety.

3.2 Transportation Requirements

- Unless otherwise specified, dangerous goods shall not be mixed in the same vehicle or container with goods containing food, medicine, animal feed and their additives.
- Unless otherwise specified, when packages of dangerous goods are loaded in the same vehicle or container as ordinary goods, they shall be segregated by one of the following means:
 - a.** Use spacers of the same height as the package.
 - b.** Maintain a spacing of at least 0.8 m from all directions.
- Before handling the faulty battery (carbonization, leakage, expansion, water ingress, etc.), the positive and negative terminals of the battery must be insulated, packed into an insulated explosion-proof box as soon as possible, and recorded in the outer box, including the transportation station name, address, time, and conditions.
- When transporting faulty batteries from the station, avoid approaching combustible storage areas, residential areas or other crowded places, such as public transport facilities or elevators.
- The product name, specifications, production date, quantity and batch number have been marked on the packaging box. Take care of the markings. If damaged, please replace in time.

3.3 Storage Requirements

- The storage environment should meet local regulations and standards.
- In case of battery failure (carbonization, leakage, expansion, water ingress, etc.), immediately move the battery to the dangerous goods warehouse for separate storage, with a distance of no less than 3m from the surrounding combustibles. Faulty batteries must be disposed of ASAP.
- When storing the battery, place it correctly according to the label on the packing box. Do not place the battery upside down, sideways or tilt it. When stacking, it should meet the stacking requirements on the outer package.
- Store batteries separately. Do not store batteries with other devices. Avoid stacking the battery too high. If a large number of batteries are stored on site, it is recommended to prepare fire fighting facilities, such as sands and fire extinguishers.
- The ambient air shall not contain corrosive or flammable gases.
- Storage environment requirements:
 - a. Ambient temperature: $-10\text{ }^{\circ}\text{C} \sim 55\text{ }^{\circ}\text{C}$,
recommended storage temperature: $0\text{ }^{\circ}\text{C} \sim 30\text{ }^{\circ}\text{C}$ (6 months);
 - b. Relative humidity: 5% RH \sim 95% RH;
 - c. Store in a dry, ventilated and clean room;
 - d. Avoid contact with corrosive organic solvents, gases and other substances;
 - e. Avoid direct sunlight;
 - f. The distance from the heat source shall not be less than two meters,
and there shall be no large amount of infrared rays;
 - g. No metal conductive dust, etc.
- During storage, proof that the product is stored according to the requirements must be available, such as temperature and humidity log data, storage environment photos and inspection reports.
- The battery must be disconnected from the outside when it is stored, and the circuit breaker must be disconnected.
- The warehouse keeper shall collect battery storage information every month, regularly report the battery inventory to the planning department, and timely recharge the batteries stored for nearly 15 months ($-10\text{ }^{\circ}\text{C} \sim 25\text{ }^{\circ}\text{C}$), 9 months ($25\text{ }^{\circ}\text{C} \sim 35\text{ }^{\circ}\text{C}$) or 6 months ($35\text{ }^{\circ}\text{C} \sim 55\text{ }^{\circ}\text{C}$).
- Extended storage requires inspection and testing by professionals before it is put into use.
- Stored batteries should be shipped on a first-in, first-out basis.
- After the production test is completed, the battery should be charged to at least 50% of the SOC before storage.



Warning

- Check the battery appearance before recharge. Only the accepted batteries can be recharged, and the unaccepted ones shall be treated as scrap batteries.
- The battery passes the appearance inspection if it is free from deformation, casing damage or leakage.

 **Warning**

- The appearance of the battery shall be inspected before the battery is recharged. Only the qualified battery can be recharged in the next step, and the unqualified battery shall be scrapped.
- The battery is deemed to pass the appearance inspection if it is free of deformation, broken casing and leakage.

Conditions Defining Extended Storage

- If the battery is deformed, damaged or leaked, it will be disposed of directly, regardless of the storage time.
- The storage time is counted from the latest charge date marked on the outer package of the battery. After the battery is ideally recharged, update the latest charge date and the next charge date on the label (the next charge date = the latest charge date + recharge interval).
- The maximum allowable period of storage and the maximum allowable recharges are 3 years or 3 recharges respectively. For example, recharge once every 8 months, with a maximum of 3 times allowed (it is recommended to refill power within 6 months). It is recommended that the battery be disposed of if the maximum allowable period of storage and recharges fall beyond the acceptable range.
- If a Li-ion battery is stored for a long time, capacity loss may occur. After 12 months of storage at the recommended storage temperature, the irreversible capacity loss of Li-ion batteries is generally 3% -10%. If customers perform the discharge test according to the specifications, they may find the battery fails to pass the test if the storage capacity of the battery is not 100% of the rated capacity.

 **Warning**

When the battery SOC decreases to 0% or the system shuts down for protection, it is necessary to recharge the battery within 7 days. The company will not provide the corresponding warranty service for the permanent failure of the battery caused by the customer's failure to recharge the battery within the maximum allowable period.

4 Installation Preparation

4.1 Installation Tools



Instruction



- When installing, ensure that your mobile phone is available and works properly.
- Ensure that the internet access is stable and fast.

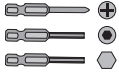
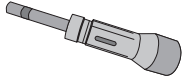

Torque wrench



Heat gun



Hammer drill



Vacuum cleaner

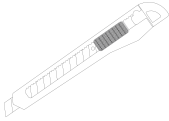

Art knife



Marker

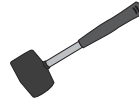

Rubber hammer



Level



Heat shrink tubing

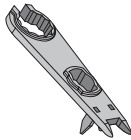

AC/PV wiring wrench



Wire stripper



Diagonal pliers

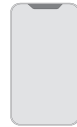

Phone & WiFi



Tape measure

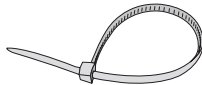

Cable tie

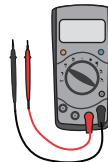

Multimeter



Hydraulic crimping pliers
(necessary)

4.2 Installation Protection



Insulated gloves



Goggles



Dust mask



Insulated shoes

4.3 Safe Installation and Operation

Danger

- Pay attention to the positive and negative terminals during equipment installation. Do not short circuit the positive and negative terminals of a battery pack or battery string, otherwise it will cause short circuit of the battery.
- Before installation and maintenance, confirm that all air switches of the product are set to OFF.
- During installation and maintenance, the related residential circuit shall be kept disconnected.

Warning

- Tighten the fastening screws of the copper bar or cable according to the torque specified in the manual. Regularly check whether they are tightened, whether there is rust, corrosion or other foreign matters, Remove them, if any. Otherwise, loose screw connections will lead to excessive voltage drop, or even burn the battery when the current is high.
- Do not place installation tools, metal parts and sundries on the equipment during installation. After the installation is completed, clean the equipment and its vicinity.
- After unpacking, place the product in the required direction. Do not place it upside down, sideways, vertically, or tilt or stack it, so as to avoid collision or drop.

Caution

- Push and move the device slowly during installation to prevent collision and scratch.
- The equipment shall be tightened firmly before starting the forklift to prevent the equipment from falling.
- Do not disassemble the protective parts on the equipment terminal, such as protective cover or waterproof cap.
- Handle the device with care, do not bump it, and ensure personal safety.
- Install and fix the equipment horizontally in a bottom-up manner and from left to right to lower the center of gravity to avoid tilt.
- After connecting and fastening the equipment, ensure that the screw spring washer is flattened, the protruding terminals on the cable are outward, and the cable is not damaged.

Check the Outer Packing

Before unpacking the product, check for visible damage, such as punctures, cracks, or other signs of possible internal damage. If any damage is found or the product is not the purchased model, do not unpack the product and contact the distributor ASAP.

Check Delivery

After unpacking the product, check whether the delivered product is complete. If any items are found missing or damaged, contact the distributor.

Please refer to the Packing List in the packing box for the quantity of delivered parts.

Before installing the battery pack, check whether the battery pack is abnormal. Battery pack abnormality refers to any of the following conditions:

- The battery pack casing is obviously deformed or damaged.
- The voltage between the positive and negative electrodes of the battery pack is far below the specified range.

4.4 Installation Location

The product can be either floor or wall mounted(Optional).

Installation angle requirements:

Do not install the equipment forward, horizontally, upside down, backward and sideways.

Installation location requirements

- Install the device on a solid brick-concrete structure or concrete wall or ground. If other types of wall and ground are selected, the wall and ground must be made of flame retardant materials and adequately strong to bear the product.
- When drilling, avoid the embedded pipes or lines to prevent short circuit or other dangers.
- Do not place anything over the equipment or cover it.
- Do not place in conditions fraught with corrosive gases or liquids.
- Do not install in areas accessible to children.
- Do not place flammable, explosive, and corrosive items around the equipment.
- Avoid low spots that are susceptible to water damage.
- Avoid environments with strong interference.
- Avoid heat or cold sources.
- Avoid places exposed to sunlight, rain or damp.
- The product should be kept at least 1 meters away from the heat source (e.g. hot water systems, gas heaters or the like) .

Installation space requirements

- When installing the equipment, ensure that there is no other equipment (except related equipment and sunshade) or inflammable and explosive articles around. Reserve adequate space for heat dissipation, safety isolation, and safe operation.
- For wall-mounting, do not place anything above or below the equipment.

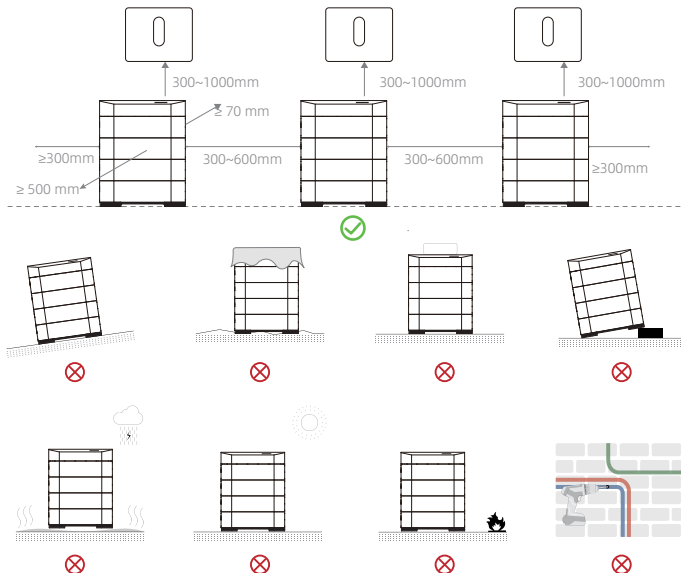

5 System Installation

5.1 Carrying and Unpacking the Product

Danger

- Observe the procedures listed in this manual and relevant international, national or regional standards, as well as industry-specific safety rules and practices before operation.
- Make sure that all protection switches for residential circuits and equipment are disconnected before installation.
- After disconnecting all batteries and AC power supply, wait at least **10 minutes** before performing any operation.

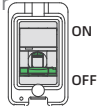

Instruction

- It is recommended to install the inverter (wall mounting) before the installation of the product.
- For installing the inverter, please refer to the user manual of inverter, which will not be repeated in this manual.

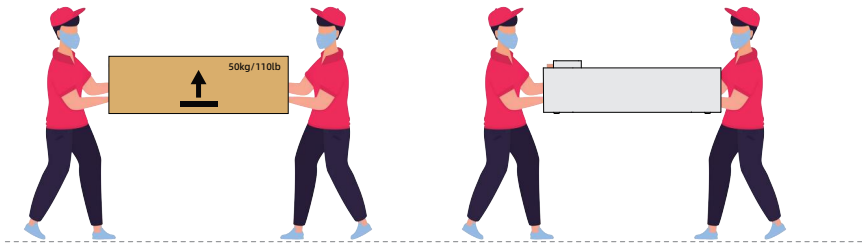

- 01** A single package is approximately 50 kg. It is recommended to be moved by two persons. Keep the product level and upward during movement.

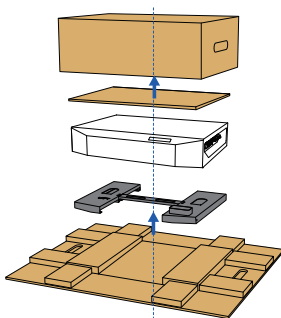

Electric control box ALOE PRO-MC5

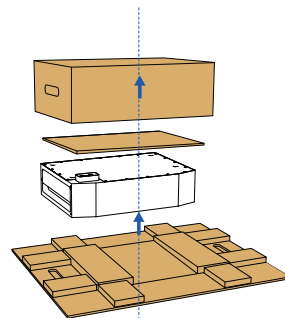

Pack ALOE-MB5

- 02** Check the outer packing. If the outer packing is intact, open up the box and check whether the products and accessories are complete.

5.2 Base Fixing

⚠ Instruction

- The following reinforcement methods are optional for customers according to their needs.
- If the product has to be operated in an area with harsh environment, such as frequent earthquakes, tsunamis, open air, and typhoons, it is recommended to take the following reinforcement methods. **Any accidents caused by failure to use the following reinforcement methods will not be covered by the product warranty.**

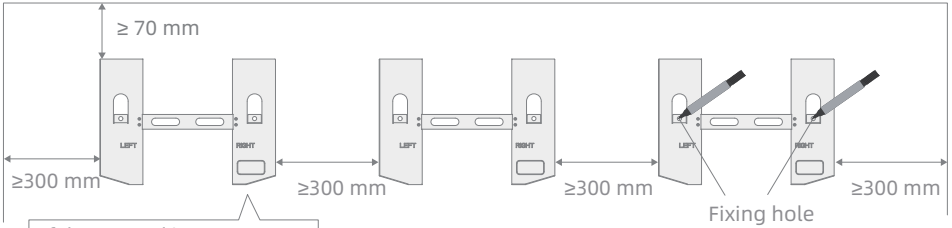

If the ground is uneven, use a leveling gasket to level it.

01 Place the base at the position to be installed, and mark the position of the fixing hole with a marking pen.

02 Drill a hole at the mark.
Hole diameter: 14 mm
Hole depth: 100mm

Instruction: Please avoid the pre-embedded pipes or lines when drilling, so as to avoid short circuit or other dangers.

03 Place the nut of the expansion screw in the hole and place the base.

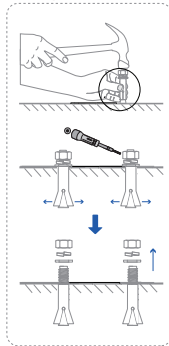

04 Fix the base to the ground with screws. The installation and fixing of the base are completed.

Complete base fixing and mounting.....

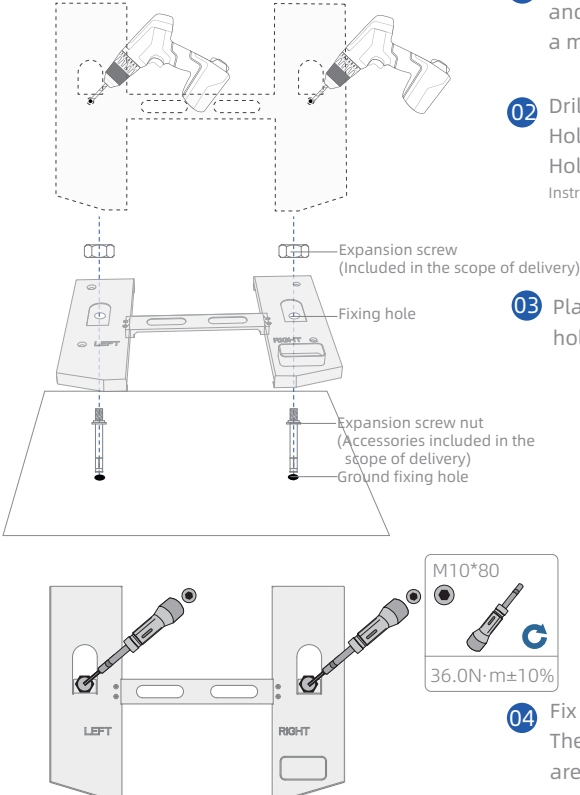

5.3 Stacking and Fixing

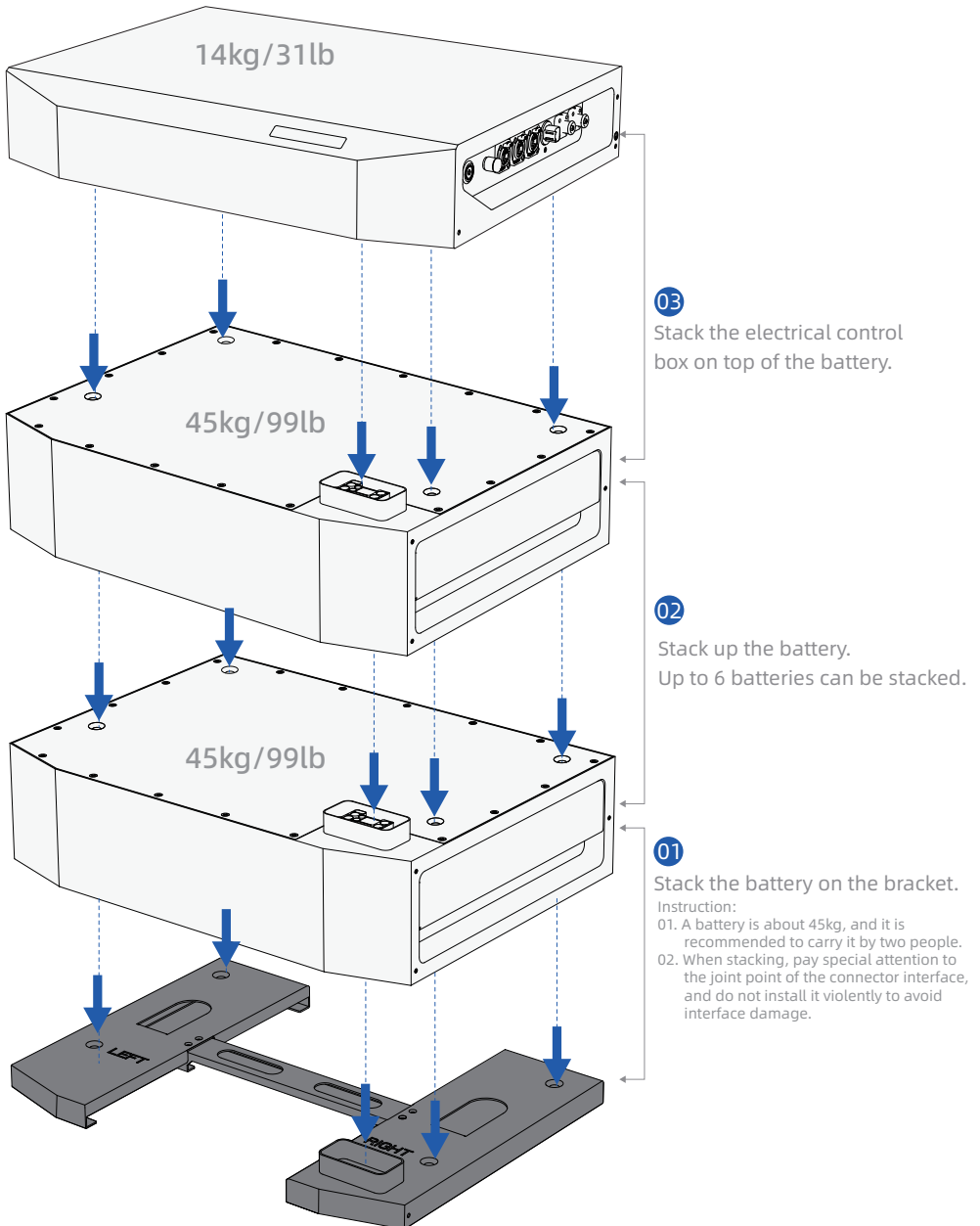

Warning

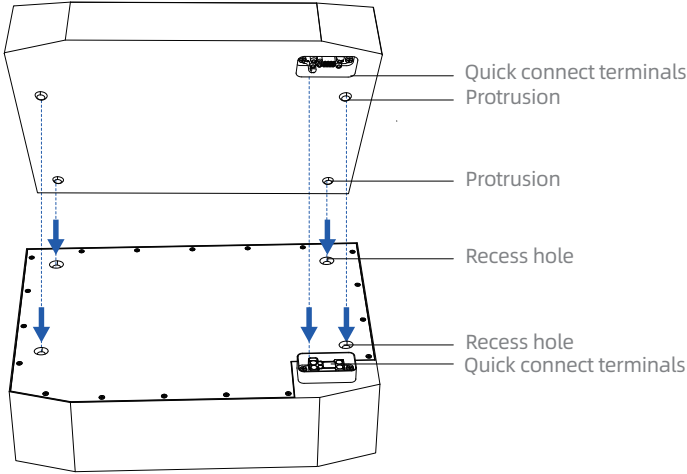

- When stacking up the equipment, slowly push and move the upper and lower positioning holes one by one to prevent collision and scratch.
- Do not disassemble the protective parts on the battery terminal, such as protective cover or waterproof cap, even if the battery is not installed.
- When moving the battery, handle it with care, do not bump the equipment, and pay ensure personal safety.

Instruction

- The following reinforcement methods are optional for customers according to their needs.
- If the product has to be operated in an area with harsh environment, such as frequent earthquakes, tsunamis, outdoor, typhoons, etc., it is recommended to adopt the following reinforcement methods.

Any accidents caused by failure to use the following reinforcement methods will not be covered by the product warranty.

Instruction

Based on the number of batteries, Tick on the corresponding model box after installing the equipment.

Rechargeable Li-ion Battery System				ROSLER CODE	
MODEL NUMBER	JA106 PRO-M6	JA106 PRO-M12	JA106 PRO-M15	JA106 PRO-M36	
Product Model	JA106 PRO-M6	JA106 PRO-M12	JA106 PRO-M15	JA106 PRO-M36	
Battery System Number	1	2	3	6	
Rated Capacity	100Ah	200Ah	100Ah	400Ah	
Rated Energy	4.8kWh	9.6kWh	5.4kWh	18.2kWh	
Rated Charging/Discharging Current	50A	100A	50A	200A	
Continuous Charging/Discharging Current	50A/40A	100A/100A	120A/120A	120A/100A	
Max. Charging/Discharging Current	65A/70A	130A/140A	120A/140A	120A/140A	
Weight	10kg	10kg	10kg	10kg	
Dimensions(WxDxH)	600*410*230mm	600*430*440mm	600*430*250mm	600*430*400mm	
Battery Type	LFP				
Battery Voltage	48Vdc				
Insulation Protection	IP54				
Protection Class	IP20				
Altitude	<+2000m				
Operating Humidity	10~95%RH				
Operating Temperature Range	-10°C ~ 45°C				
JA106 PRO-M6 (100Ah/48Vdc)	JA106 PRO-M12 (200Ah/48Vdc)	JA106 PRO-M15 (100Ah/48Vdc)	JA106 PRO-M36 (400Ah/48Vdc)		
Address: No. 28, Wenhui Road, Jiangsu Province, China	Address: No. 28, Wenhui Road, Jiangsu Province, China	Address: No. 28, Wenhui Road, Jiangsu Province, China	Address: No. 28, Wenhui Road, Jiangsu Province, China		

WARNING

This product must be grounded.
 Battery cannot be short-circuited.
 Do not touch or use if liquid spills on it.
 Be careful of high surface temperature.
 Keep the unit away from children or liquid.
 Do not disassemble or repair it without repair.
 Keep the product away from children and pets.

SN
MAC

• **Fixing the equipment enclosure**

01 Take out the accessory bag.



02 Attach the anti-scratch sticker to the inside of the fixing part.

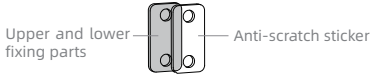

03 Tighten the screws on the equipment. Both sides are installed in the same way.

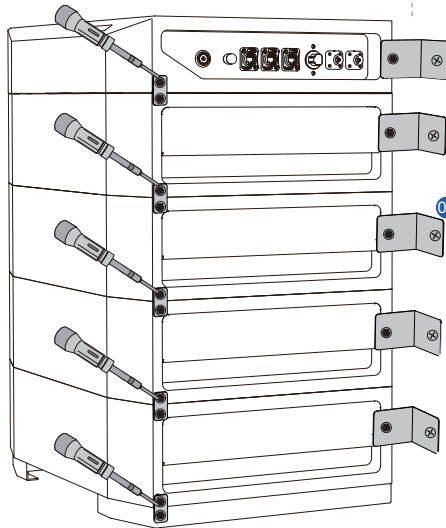

• **Fixing the equipment to the wall(Optional)**

01 Place the installation positioning plate(delivered accessory) on the installation and mark the fixing hole.

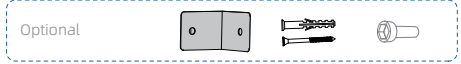

02 Drill in the marked location.
Drill bit diameter: 8mm
Hole depth: 100mm

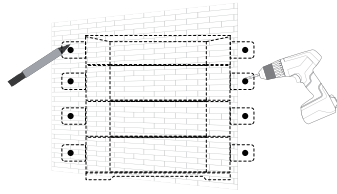

03 Secure the fixing plate to the equipment with screws.

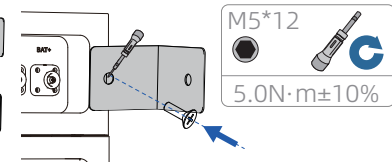

04 Secure the fixing plate to the wall with expansion screws. Both sides are installed in the same way.

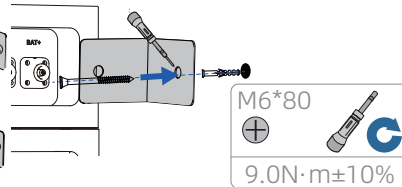

Fixing the equipment enclosure

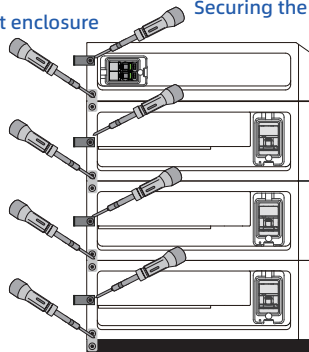

Securing the equipment to the wall

6 Electrical Connection

Danger

01. Observe the procedures listed in this manual and relevant international, national or regional standards, as well as industry-specific safety rules and practices before operation.
02. Make sure that all protection switches for residential circuits and equipment are disconnected before installation.

Installation sequence:

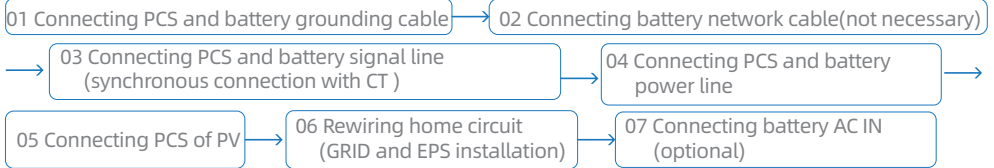

-  **Warning** 01. Please refer to the inverter installation instructions for the installation of the inverter system.
02. The inverter must be installed horizontally on the wall.

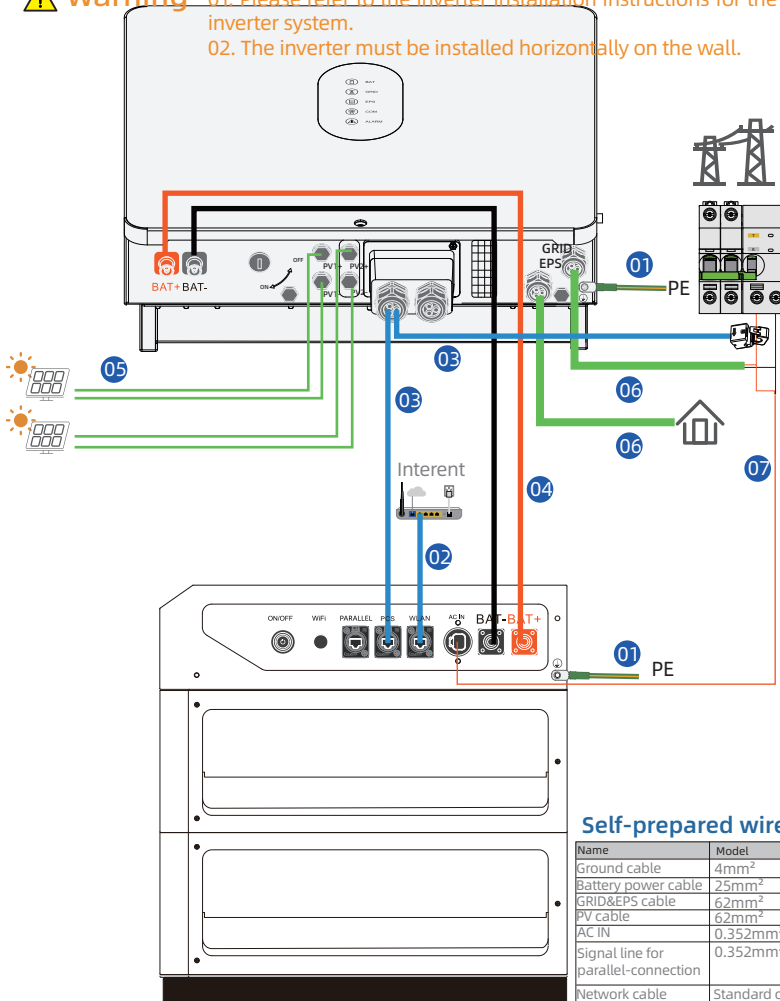

Self-prepared wire harness

Name	Model
Ground cable	4mm ² Single core hard copper
Battery power cable	25mm ² Single core hard copper
GRID&EPS cable	62mm ² Three core multi-strand
PV cable	62mm ² Two core multi-strand
AC IN	0.352mm ² Two core single strand
Signal line for parallel-connection	0.352mm ² Two core single strand + two core shielded twisted pair
Network cable	Standard cable 100M CAT5

6.1 Grounding Cables Connection of PCS and Battery

⚠ **Instruction**

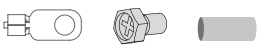
Delivered accessory 

Grounding wire making

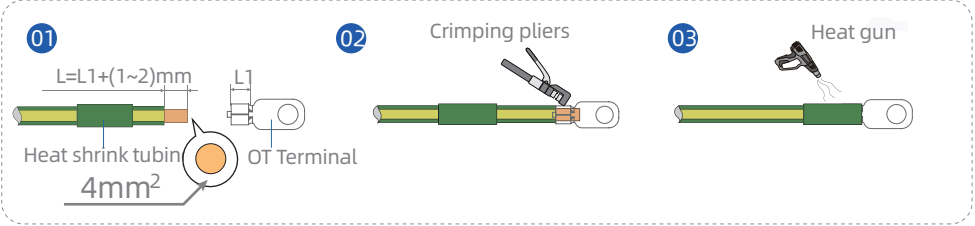

6.2 Battery Network Cables Connection

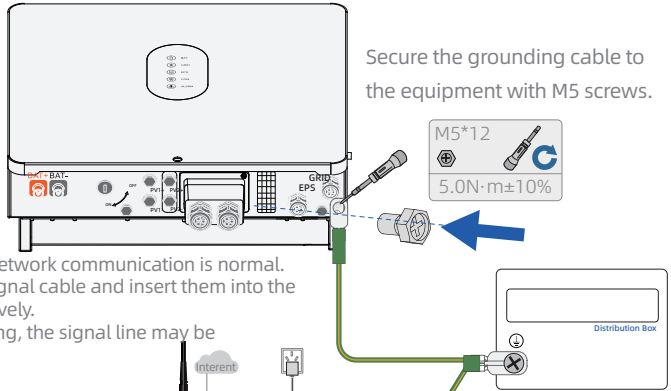

Please ensure that the home network communication is normal. Take out the two ends of the signal cable and insert them into the equipment and router respectively. (If the family WiFi signal is strong, the signal line may be unnecessary.)

- Please install the equipment communication cable according to the actual situation. The recommended length is less than 3m.
- Please ensure that the network communication is normal.
- Communication supports the standard RJ45 connector and the port is the local area network port (service port). The definition is as follows:

Definition of the RJ45 connector



No.	Colour	WLAN
01	Orange-white	T568B
02	Orange	
03	Green-white	
04	Blue	
05	Blue-white	
06	Green	
07	Brown-white	
08	Brown	

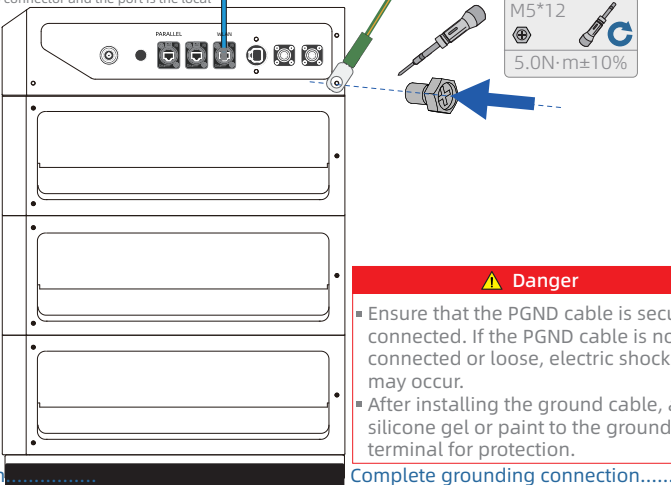

⚠ **Danger**

- Ensure that the PGND cable is securely connected. If the PGND cable is not connected or loose, electric shocks may occur.
- After installing the ground cable, apply silicone gel or paint to the ground terminal for protection.

Complete signal line connection.....

Complete grounding connection.....

6.3 PCS and Battery Signal Line Connection (Synchronously connecting CT)

⚠ Instruction

Delivered accessory

4PIN Communication terminal



RJ45



CT

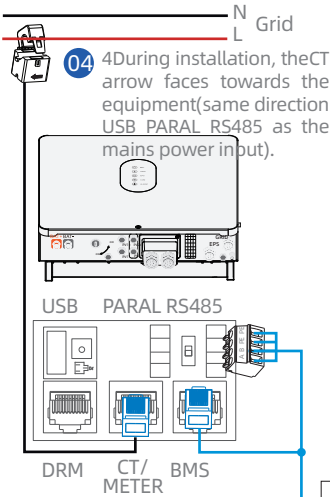

04 During installation, the CT arrow faces towards the equipment (same direction USB PARAL RS485 as the mains power input).

01 Remove the waterproof cover and loosen the rubber nut on the waterproof cover.

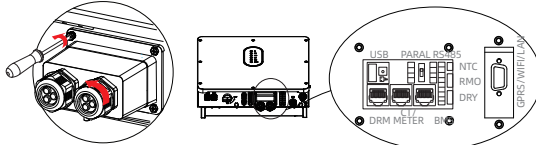

02 Make RJ45 and BMS terminals according to the functional description defined above for each pin. Thread the BMS cable through the rubber nut, seal, and waterproof cover in turn.

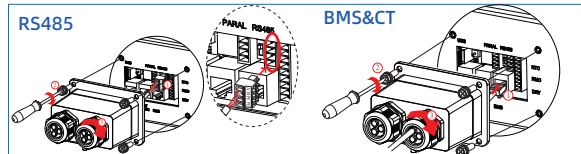

(RS485) 4PIN communication terminal (BMS) RJ45

PIN	A	B	PE	PE
Function Description	485A-2 (PCS)	485B-2 (PCS)	PE	NC
Color	Orange	Orange white	NC	NC

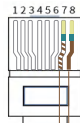

No.	Color	BMS
01	NC	NC
02	NC	NC
03	NC	NC
04	NC	NC
05	NC	NC
06	NC	NC
07	Brown white	CAN2L(PCS)
08	Brown	CAN2H(PCS)

RS485_A
About 50mm is recommended

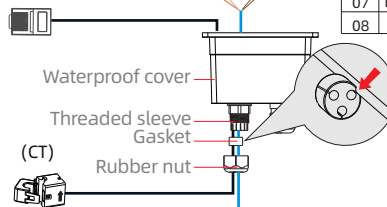

⚠ Ensure every cable will pass through the sealing gasket; Don't clamp the sealing ring.

(PCS) RJ45

No.	Color	PCS
01	Orange white	485B-2(PCS)
02	Orange	485A-2(PCS)
03	NC	485B-1(VPP)
04	NC	CAN1H
05	NC	CAN1L
06	NC	485A-1(VPP)
07	Brown white	CAN2L(PCS)
08	Brown	CAN2H(PCS)

Standard cable 100M CAT5

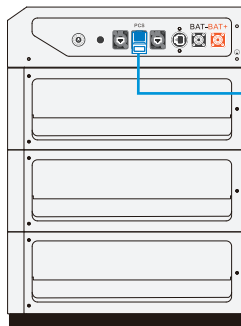

03 Insert the terminal into the appropriate port. Screw the waterproof cover firmly back onto the inverter with four M4 screws (1.2N·m). Install the seal into the threaded sleeve and tighten the rubber nut.

Complete PCS and battery signal line connection & CT connection.....

6.4 PCS and Battery Power Cable Connection

Warning

- Polarity reversal will damage the inverter!
- To reduce the risk of injury, use the cables with recommended size.
- To avoid electric shock, please disconnect all DC circuit breakers on the battery side. This will ensure that the inverter can be safely disconnected during maintenance.

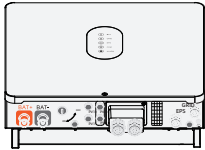

 It is recommended that the battery cable $\leq 3m$

Making inverter plug

01

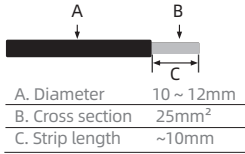

02

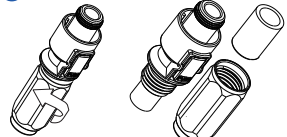

Instruction: Do not damage the core wires when peeling cables.

03

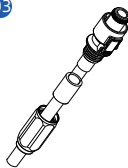

04



05

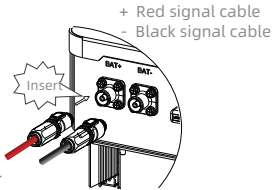

 Hydraulic crimper
Select 25mm² size

Making battery plug

01

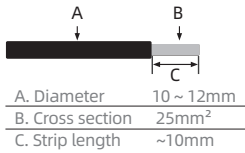

Notice

Do not damage the core wires when peeling cables.

03 Insert the core wire into the crimp terminal and rivet it.

The bare core cable is less than 1mm

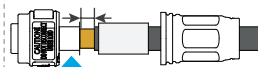

 Hydraulic crimper
Select 25mm² size

04 Push the seal to the terminal position.

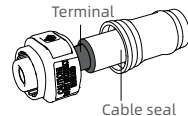

05 Push the tail cover to drive the seal to the thread, and use a wrench (1.0~1.5N·m) to secure the tail cover to the plug.

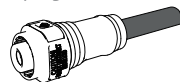

02

Select cables based on connector specifications and route them through the tail cover and seal (pay attention to the direction of the seal).

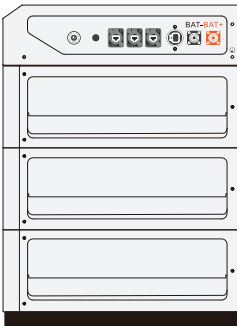
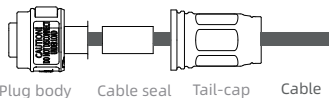

Complete PCS and battery power cables connection.....

6.5 PV-PCS Connection

⚠ Danger

- Ensure that the interface and polarity are correctly connected during installation. Do not short-circuit the positive and negative terminals. Otherwise, the battery may be shortcircuited and the equipment may be damaged.
- Before connecting the PV, ensure that the parameters comply with the device requirements (product labels or product specifications).
- Any equipment damage or personal injury or death caused by knowingly connecting to a current that does not meet the equipment parameters is not covered by any warranty.

01

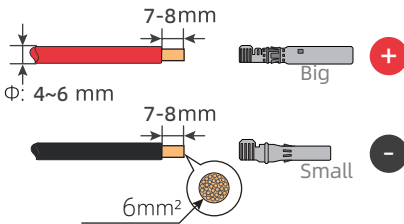

Instruction:



02

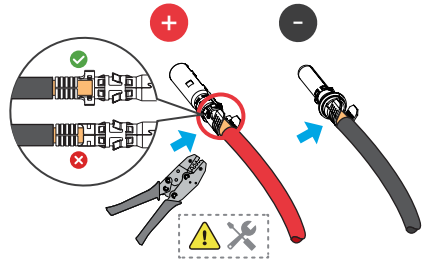

Instruction:

Harness crimping must be firmly in place.

03

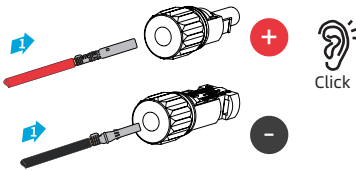

Instruction:

Insert the connector directly into place.

04

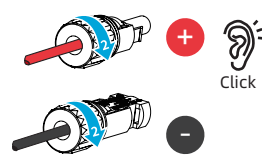

Instruction:

Screw the cover tightly to ensure the seal is waterproof.

05

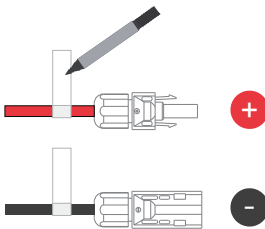

Instruction:

Label each harness to facilitate later maintenance.

06

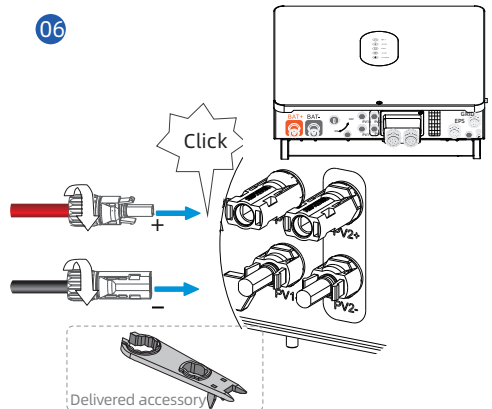

Instruction:

For any unexpected insertion, please use the disassembly tool to carefully remove the plug.

Complete PV connection and the hardware installation.....

6.6 Home Circuit Rewiring (GRID & EPS Connection)

In order to supply power more safely and efficiently, it is recommended to redesign the household circuit during installation. Skip this procedure if circuit rewiring is not required. There are three methods for home circuit rewiring:

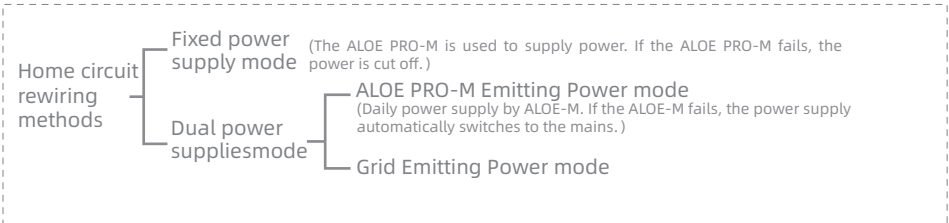

⚠ Danger

- This operation must be performed by a locally certified electrician.
- Before operation, please strictly abide by the "User manual", relevant international, national or regional standards, as well as industry-specific safety rules and practices.
- Do not perform any operation until the system is completely powered off.
- The total power of the load must be less than the total power of ALOE PRO-M. Overload will cause alarm or even automatic shutdown.

High power home appliances (only for reference)			
Kettle	2kW	Microwave	1.5kW
Induction Cooker	3kW	Oven	2kW
Refrigerator	2kW	Toaster	2kW
EV Charging Pile	7kW	Bath Heater	3kW
		Hairdryer	1.6kW
		Electrical Water Heater	2kW
		TV	0.3kW
		Air Conditioner	2kW
		High-power Audio	1kW

⚠ Instruction

The materials needed for home circuit rewiring should be purchased by the user. If home circuit redesign is not required, skip this procedure.

6.6.1 Dual Power Supplies Mode

⚠ Caution

When installing an automatic converter of dual power supplies, set the converter switch to automatic mode.

⚠ Instruction

Dual power supplies mode includes grid emitting power mode and ALOE PRO-M emitting power mode.

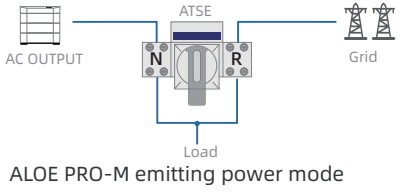
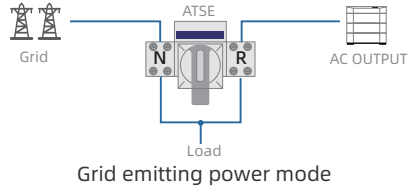

6.6.1 Dual Power Supplies Mode (The schematic diagram shows the ALOE PRO-M emitting power mode.)

Caution

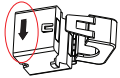

When installing, please keep the CT arrow pointing towards the direction of the mains power input.

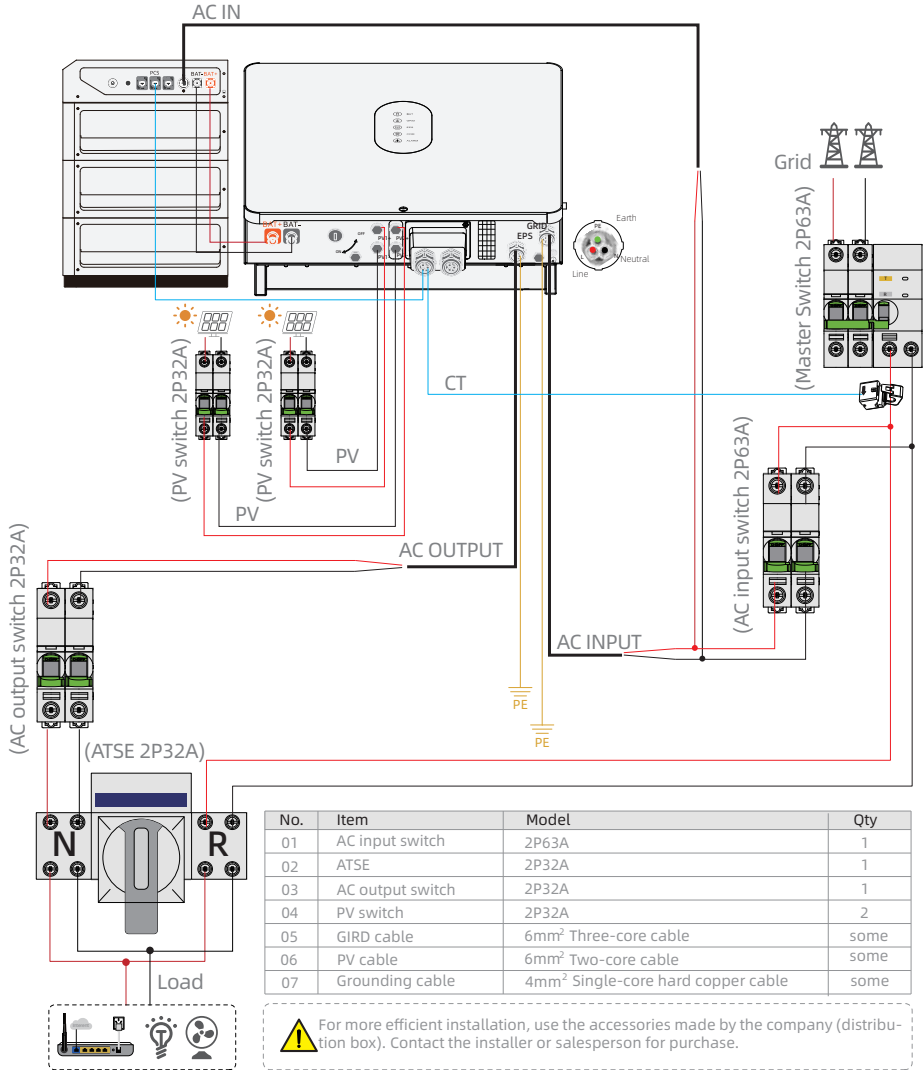

The total load power must be less than the total power of ALOE PRO-M. Overload will cause alarm or even automatic shutdown.
 If the equipment stops frequently, check whether it is overloaded. Reduce loads for the equipment that stops running as a result of overload.

6.6.2 Fixed Power Supply Mode

⚠ Caution

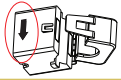

When installing, please keep the CT arrow pointing towards the direction of the mains power input.

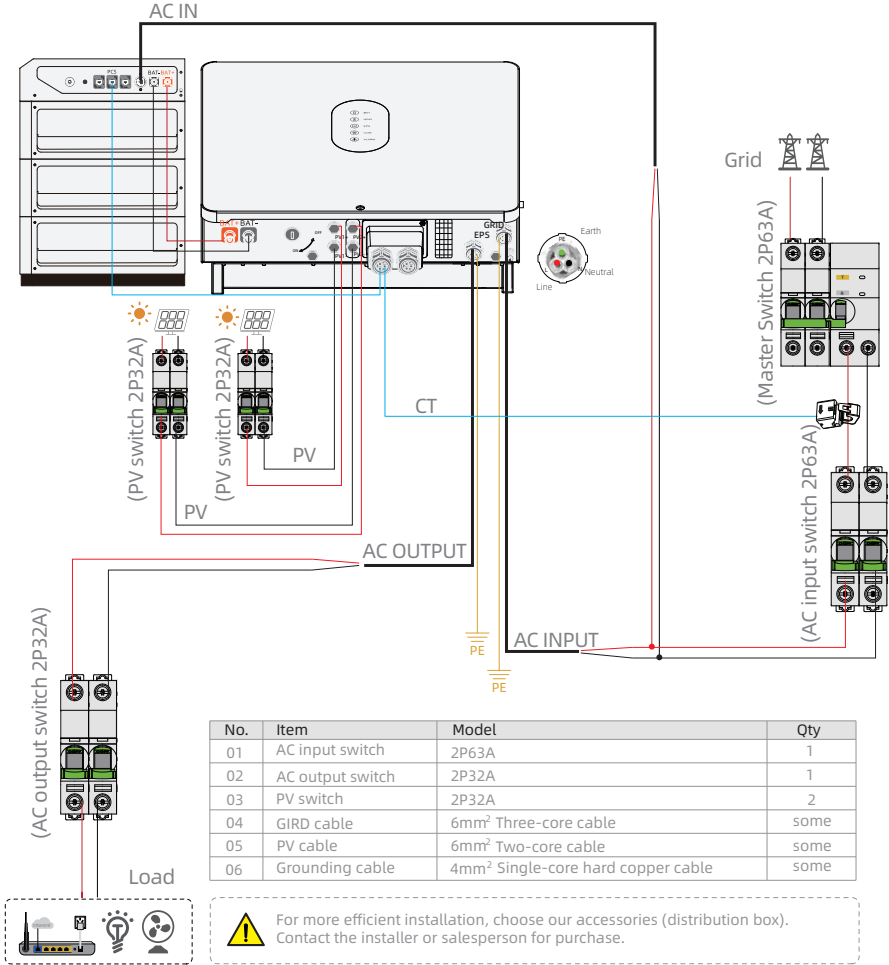

The total load power must be less than the total power of ALOE PRO-M. Overload will cause alarm or even automatic shutdown.

If the equipment stops frequently, check whether it is overloaded. Reduce loads for the equipment that stops running as a result of overload.

6.6.3 Home Circuit Rewiring (GRID and EPS connection)

Danger

Before connecting the GRID/EPS terminals, ensure that the AC and DC terminals are powered off and the PV switch is turned off. Otherwise, there is a risk of high-voltage electric shock.

Instruction

Step 1: Assemble the AC connector and plug the AC connector into the GRID/EPS port.

- 01 Use cables with multi-copper core designed for outdoor usage.

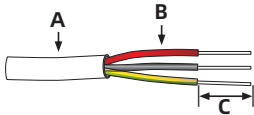

A. Diameter	14 ~ 20/10~14mm
B. Cross section	8~14/4~6mm ²
C. Strip length	~10mm

02

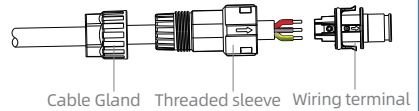

- 03 ① Tighten the three screws, ensuring that each nut does not exceed the surface.
② The cable cross-section is shown in the figure.
③ Tighten the nut.

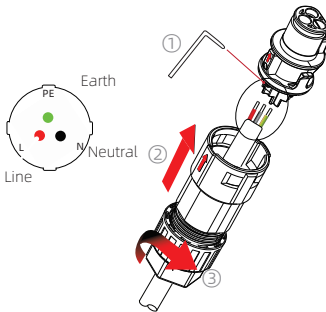

04

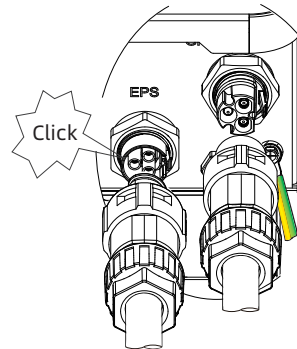

Step 2: Connect the AC circuit breaker. An AC circuit breaker should be installed between the inverter and the GRID/EPS.

- Before connecting the inverter AC cable to the AC circuit breaker, ensure that the AC circuit breaker works properly. Keep the AC circuit breaker disconnected.
- Connect the PE wire to the ground electrode, and connect the N and L wires to the AC circuit breaker.
- Connect the AC circuit breaker to the GRID/EPS.

Caution

- Multiple inverters are not allowed to share one circuit breaker.
- No load is allowed between the inverter and the AC circuit breaker.

To ensure that the inverter can be safely and reliably disconnected from the grid, only one AC circuit breaker (≥50A) can be installed on the inverter GRID/EPS port.

Inverter (GRID and EPS) connection completed.....

6.7 Battery AC IN Connection

⚠ Instruction

Under normal circumstances, installers are not required to mandatorily install this connection during installation. When the battery system is in a severe fault condition and is unable to supply power to the EMS controller in the PDU, AC power can be temporarily connected to the EMS to keep it powered and allow it to continue monitoring the system status.

- 01 Peel the core wire.

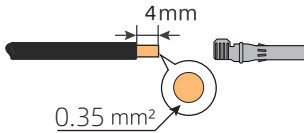

- 02 Insert the core wire into the terminal and rivet it in the crimping die.

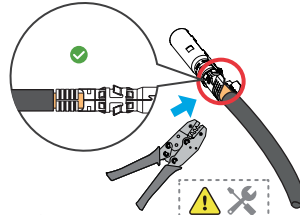

Notice:
Harness crimping must be firmly in place.

- 03 Push the terminal vertically into the connector. Pay attention to the position of the zero and fire lines.

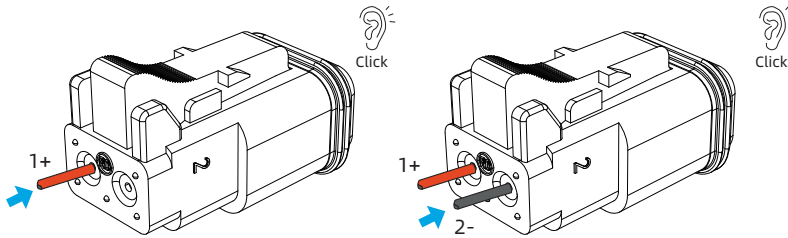

Notice:
When the crimped cable is inserted into the connector, a "click" sound is heard.

- 04 Push the platen and insert the platen completely.

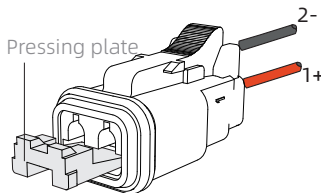

- 05 Insert the terminal into the corresponding port.

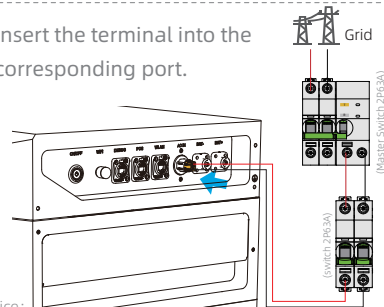

Notice:
When the crimped cable is inserted into the connector, a "click" sound is heard.

AC IN connection completed, system installation completed.

7 Commissioning and Operation

Danger

- Please use special protective equipment and insulation tools to avoid electric shock or short circuit.
- Observe while powering on. If any abnormality is found, power off the battery immediately, pinpoint the cause, and power on after solving the problem.
- When the battery is disconnected for installation and commissioning or finishes discharging, please recharge the battery in time, otherwise it may be damaged due to overdischarge.
- Storing the batteries with low SOC may cause battery failure due to overdischarge. Please recharge the battery in time.

Warning

- Before powering on the equipment for the first time, the parameters shall be set correctly by professionals.
- Incorrect settings may lead to inconformity with the power grid requirements of the country/region, impacting the normal operation of the equipment.

7.1 Inspection Before Power-on

- Switches: All switches in the household circuit and all switches connected to the energy storage system are in the "OFF" state.
- Grounding: The ground wire is connected correctly and firmly.
- Cable connection: AC output line, DC input line, power line and signal line are connected correctly and firmly.
- Cable layout: The cable layout is reasonable and tidy to meet the user's requirements.
- Binding of cable ties: The cable ties shall be evenly distributed, and no sharp corner shall be caused at the cut.
- Installation of energy storage system : The installation is correct, firm and reliable.
- Installation environment: The installation space is reasonable, the environment is clean and tidy, and there are no construction remnants.
- Unused terminals and connectors: Put waterproof covers on unused terminals and connectors.

8 Parallel-connection of the System

ALOE PRO-M can be parallel-connected, and the parallel-connection mode is divided into single-phase AC output and three-phase AC output.

Single-phase AC output mode can support up to 6 parallel-connected sets, while three-phase AC output mode only supports 3 parallel-connected sets .

Instruction

Before parallel-connection, it's necessary to calibrate the output voltage, DC component, and battery voltage of the inverter for each set. In theory, the more accurate the calibration, the better the performance. The calibration deviation between the inverter output voltage and battery voltage should be within $\pm 1V$, and the DC component calibration should be within $\pm 50mV$.

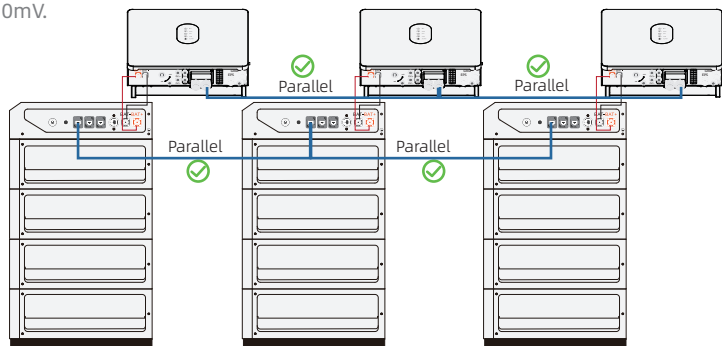

Three-phase AC output mode

3 parallel-connected sets of ALOE PRO-M:

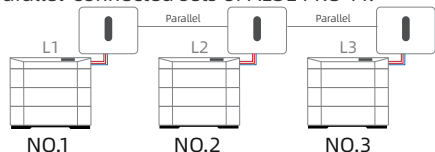

Warning

- This product does not support three-phase equipment with delta connection, so as to avoid damage to the equipment.
- The AC input side must be three-phase in parallel-connection of three-phase AC output mode, and the three-phase input must be consistent with the output. Wrong phase connection might lead output short circuit.

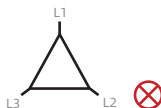
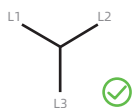

Single-phase AC output mode

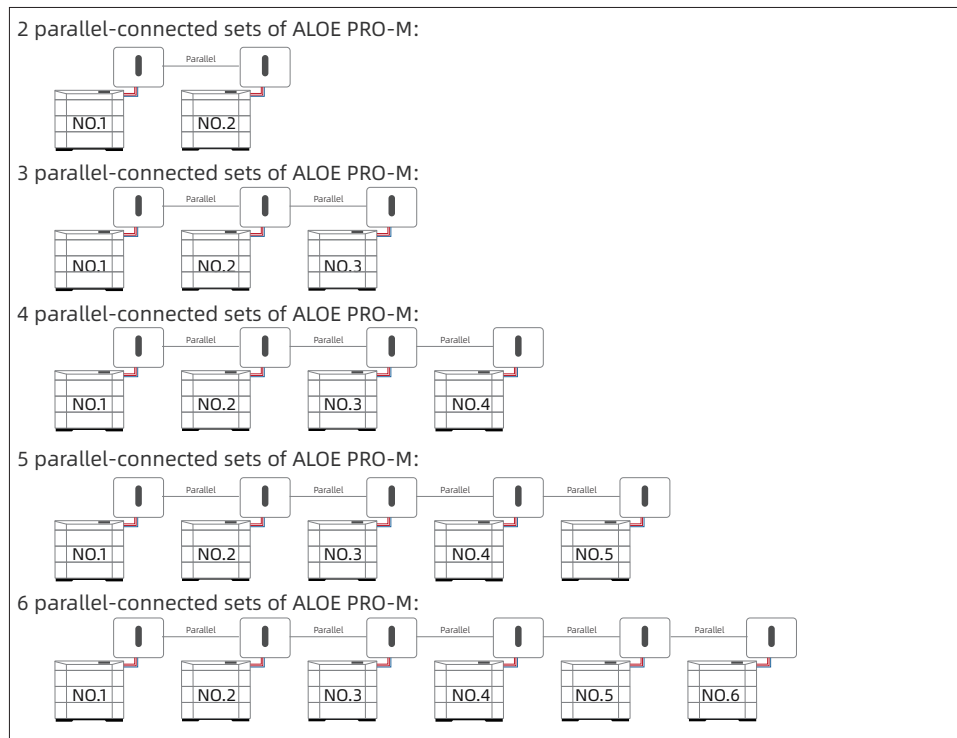

Single system ready for operation

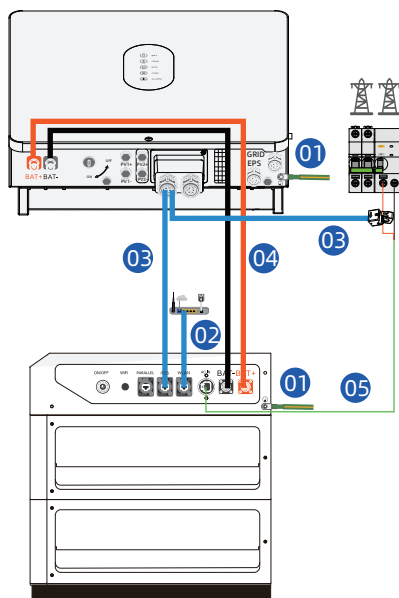

Preparation before parallel-connection

- 01 PCS and battery ground cable connection
- 02 Battery cable connection (optional)
- 03 PCS and battery signal line connection (CT synchronous connection)
Install the waterproof box in the original way after the parallel-connection is complete
- 04 PCS and battery power cable connection
- 05 Battery AC IN installation (optional)



When multiple sets are parallel-connected (Single-phase) only one CT can be installed.
When multiple sets are parallel-connected (Three-phase) must three CT can be installed.

Parallel setup steps

- a Inverter(>3) DIP switch operation
- b Parallel-connection of signal line
- c PCS-PV installation
- d Home circuit rewiring (GRID and EPS installation)
- e Parallel-connection parameter setting
- f Restart. Setting completed.

8.1 Dial Switch Operation

- 01 Remove the waterproof cover and loosen the rubber nut on the waterproof cover.

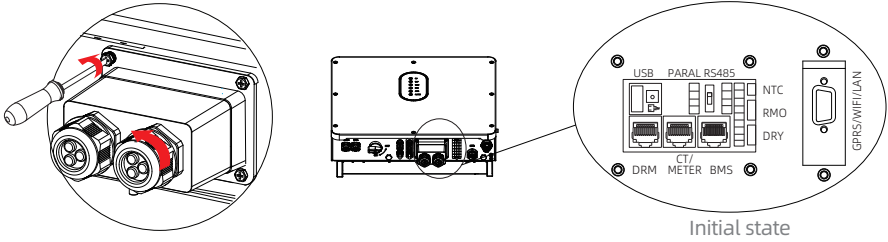

- 02 Parallel-connection switches of all inverters are in the "ON" position by default before delivery. Only when 3 or more inverters need to be connected in parallel will it be necessary to turn the parallel switches back to "OFF".

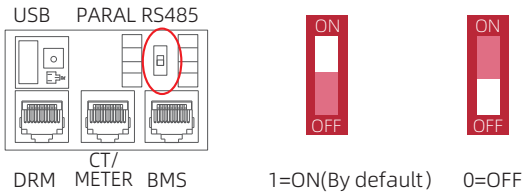

Instruction

The rules for dialing back are as follows:

2 sets in parallel-connection: no need to dial back:

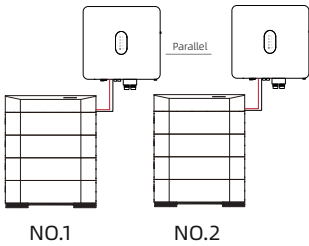

3 2 sets in parallel-connection: 101 (dial back the second set to OFF (1=ON, 0=OFF)):

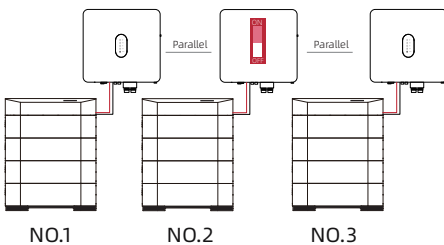

4 sets in parallel-connection: 1001 (dial back the second and the third sets to OFF (1=ON, 0=OFF)):

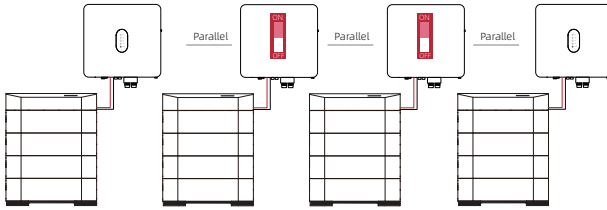

NO.1

NO.2

NO.3

NO.4

5 sets in parallel-connection: 10001 (dial back the second to the fourth sets to OFF (1=ON, 0=OFF)):

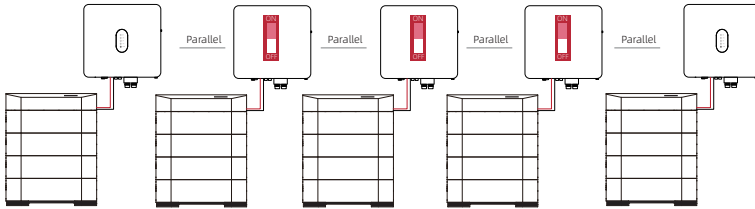

NO.1

NO.2

NO.3

NO.4

NO.5

6 sets in parallel-connection:: 100001 (dial back the second to the fifth sets to OFF (1=ON, 0=OFF)):

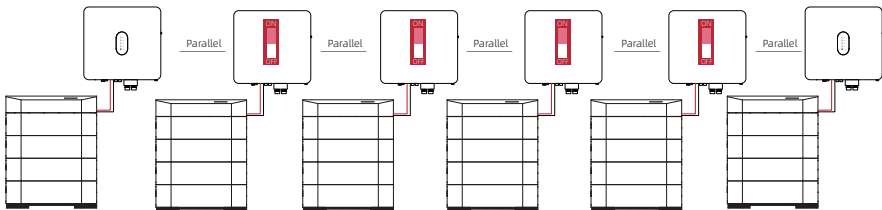

NO.1

NO.2

NO.3

NO.4

NO.5

NO.6

Complete DIP switch operation.....

8.2 Connection of Signal Line

8.2.1 Parallel-connection of signal line of inverter (Only one CT can be installed)

- 01 Remove the waterproof cover and loosen the rubber nut on the waterproof cover. Skip this step if the cover has been removed previously.
- 02 Prepare wiring terminals (Connect terminals according to corresponding functions).

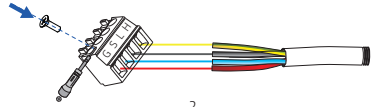
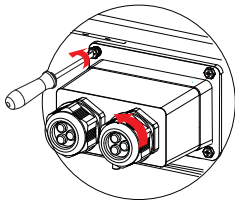

4PIN Communication terminal 0.35mm Four core single strand

PIN	G	S	L	H
Function Description	GND_S	PARA_SYNC	CAN_L	CAN_H

- 03 Insert the 4-PIN communication terminal into the appropriate port.

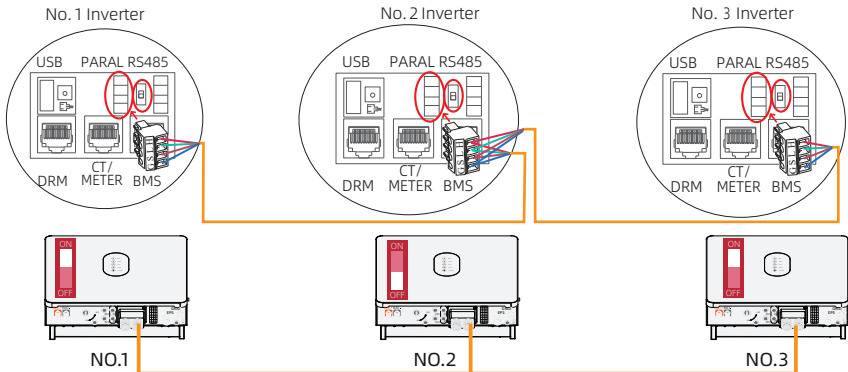

- 04 Screw the waterproof cover back into the inverter with four M4 screws (1.2 N·m). Install the seal into the threaded sleeve and tighten the rubber nut.

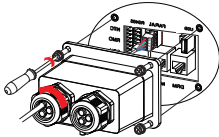

Parallel-connection of signal line

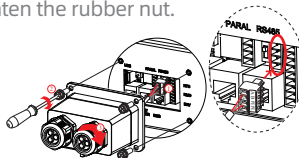

RJ45

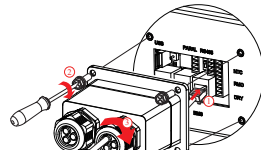

BMS and CT

8.2.2 Parallel Connection of Battery Signal Line



Insert port extender at PARALLEL.
Failure to install terminat resistance will lead to dysfunction of the parallel-connection communication.

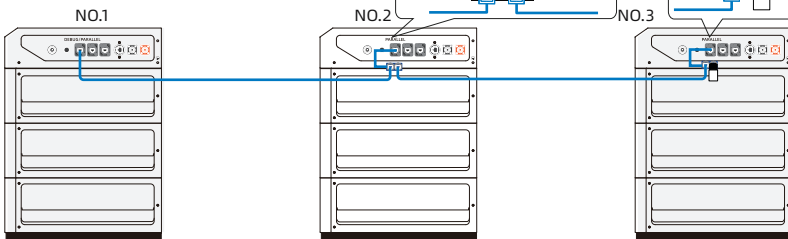

Completed Parallel-connection of Signal Line.....

8.3 Connection of PV

Danger

- PV panels cannot be connected to each inverter in parallel. Each inverter needs to be connected to P V panels separately. It is recommended to evenly match inverter with PV panels of the same type.
- Before connecting PV, please ensure that the PV parameters meet the requirements of the equipment . The company will not be liable for any equipment damage or casualties caused by the access to the PV whose parameters contradict the required PV inverter.

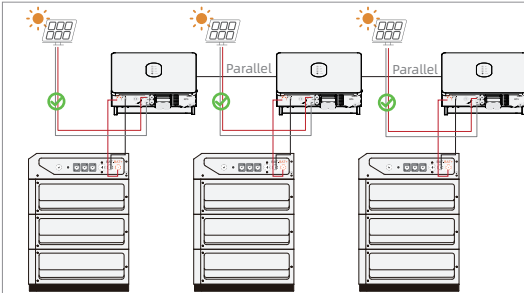

PV panels shall not be connected in parallel to each inverter

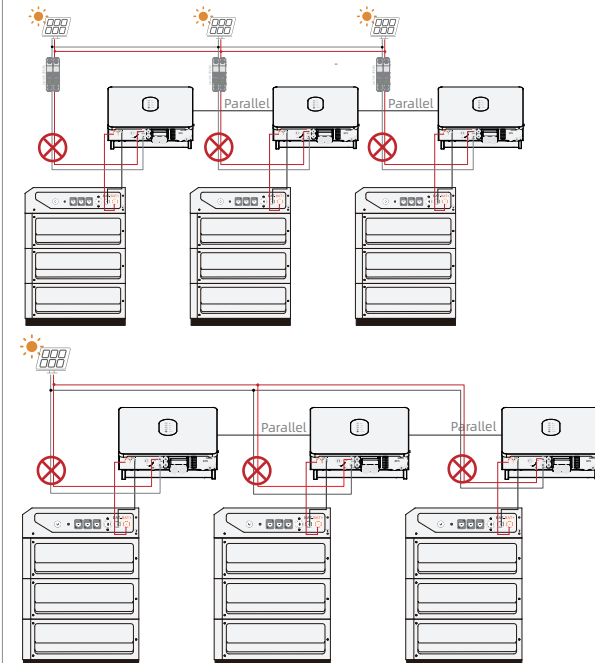

Parallel-connection of PV completed.....

8.4 Connection of GRID & EPS

8.4.1 Single-phase AC Output Mode (The following shows 3 parallel-connected sets. The rest parallel-connected sets can be installed in the same way.)

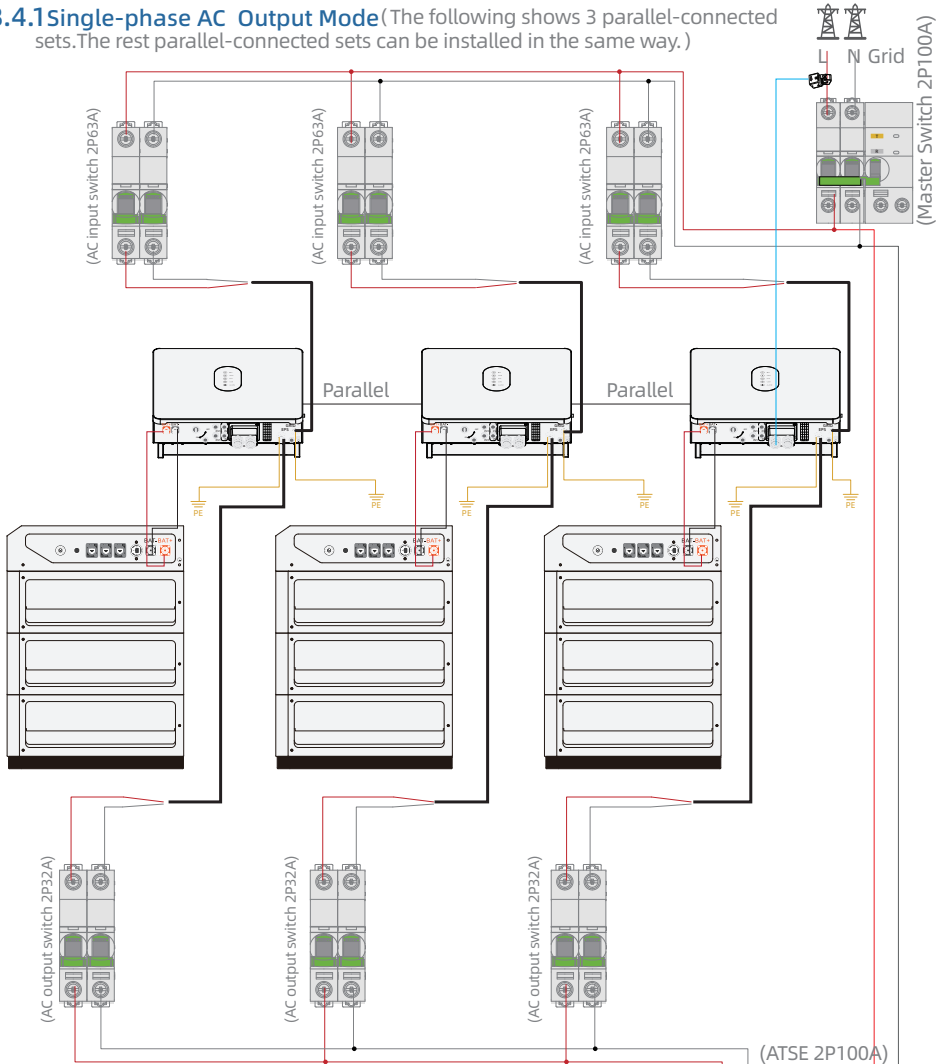

No.	Item	Model	Qty
01	Input switch	2P63A	N
02	ATSE	2P100A	1
03	Output switch	2P32A	N
04	PV switch	2P32A	M
05	GRID cable	6mm ² Three-core cable	some
06	PV cable	6mm ² Two-core cable	some
07	Grounding cable	4mm ² Single-core hard copper cable	some

N: Number of parallel machines M: Number of PV accesses

- ⚠ For more efficient installation, you can purchase the company's accessories (distribution box). Contact the installer or salesperson for purchase.
- ⚠ For information about PV connection, refer to Page 46.
- The models of ATSE and Master switches vary according to the number of the product connected in parallel, as shown in the table below.

Number of parallel	1	2	3	4	5	6
Models of ATSE and Master switches	2P32A	2P63A	2P100A	2P125A	2P160A	2P200A

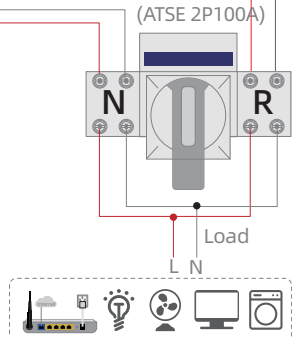

8.4.2 Three-phase AC Output Mode

(The figure shows three parallel-connected sets.)

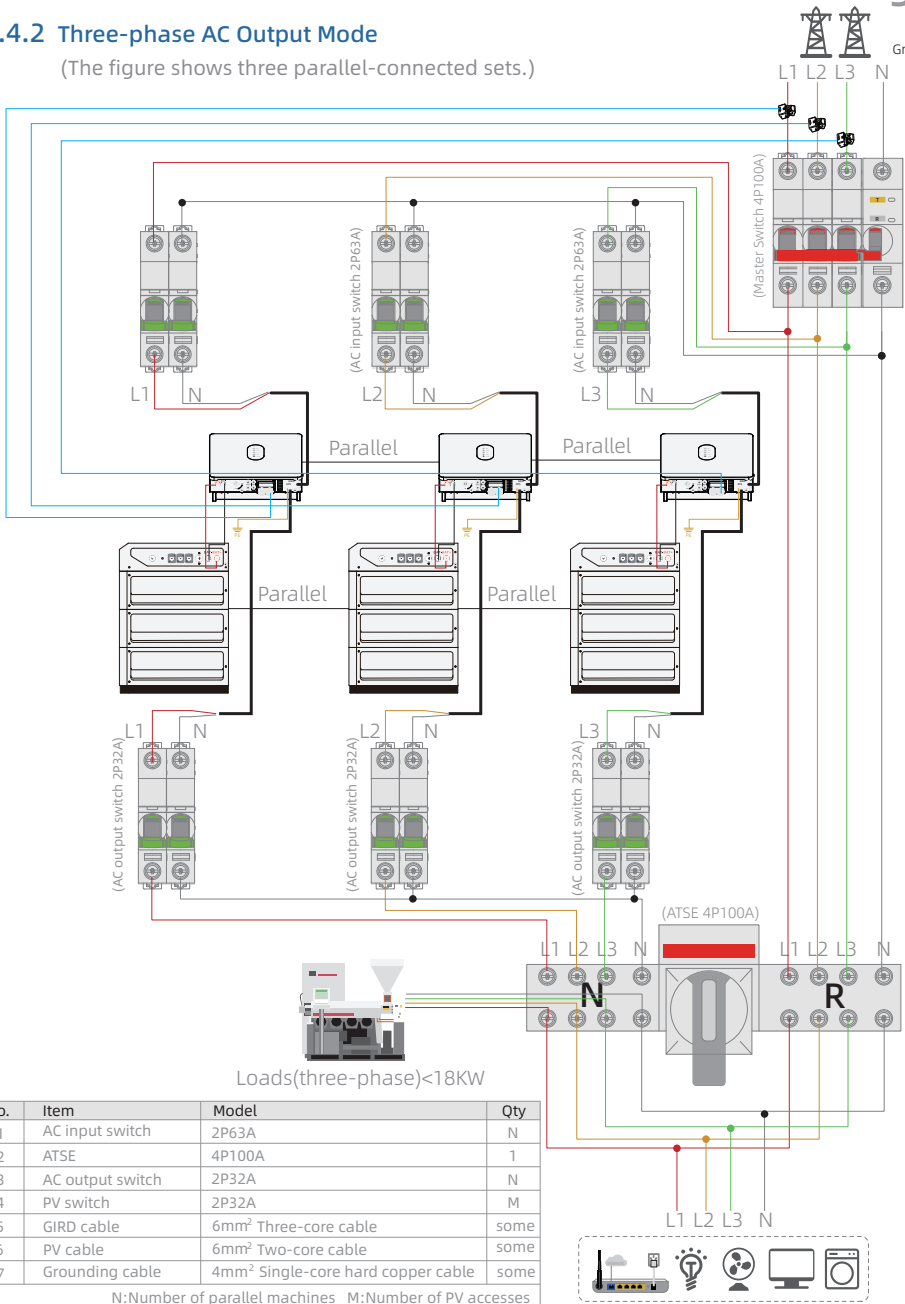

No.	Item	Model	Qty
01	AC input switch	2P63A	N
02	ATSE	4P100A	1
03	AC output switch	2P32A	N
04	PV switch	2P32A	M
05	GIRD cable	6mm ² Three-core cable	some
06	PV cable	6mm ² Two-core cable	some
07	Grounding cable	4mm ² Single-core hard copper cable	some

N: Number of parallel machines M: Number of PV accesses

- ⚠ For more efficient installation, you can choose our accessories (distribution box). Contact the installation personnel or salesperson for specific purchase option.
- For information about PV connection, refer to Page 46.
- The models of ATSE and Master switches vary according to the number of machines in parallel, as shown in the table below.

Number of parallel	1	2	3	4	5	6
Models of ATSE and Master switches	2P63A	2P63A	2P100A	2P125A	2P160A	2P200A

8.5 Parameter Setting for Parallel-connection

Danger

- Before commissioning, ensure that the cable connection is correct and the grounding connection is effective and firm. **Do not connect to EPS.**
- Ensure that all circuit breakers in the load side are disconnected and that each neutral line of the inverter is connected together.
- Parallel-connection must be done by professionals. Users are forbidden to parallel-connect the product.

01 Turn on the grid switch or the battery switch to activate the inverter. The inverter is in the standby mode.

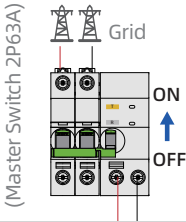

or

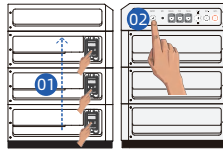

02 The inverter lights up.

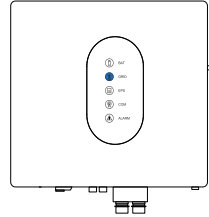

Enter the setting interface on the APP (The setting is only necessary for one set of the product and the first set of the parallel-connected sets is recommended.)

Notice

One set of the product can be bound to one installation program only.

For the sake of user's privacy, after finishing and exiting from the bind operation, the installer cannot review data and information unless the user provides a MAC address.

01 Obtain the MAC address and QR code from the user: Log in from the "User" page of the account and click the Settings page.

Click in the following sequence to view the MAC code and QR code of the device.

User's mobile phone

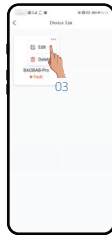
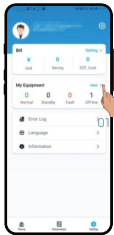

02 After login, click and enter the "Settings" page, and then click "Scan code" to scan.

The installer's mobile phone

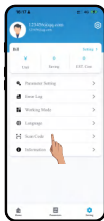

User's mobile phone

The installer's mobile phone

Notice

01. Binding serves to log service records.
02. The installer can check the binding record on the iPotisEdge platform after the equipment is bound.
03. Please obtain the website of the platform from the manufacturer.

Parameter Setting: Single-Phase AC Output Mode

01 Log in to enter the parallel-connection setting page.

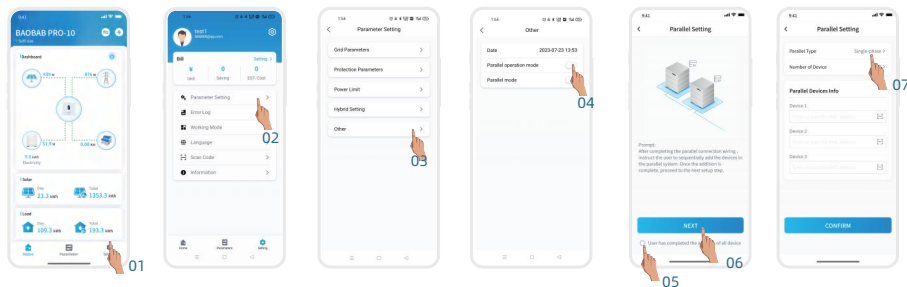

02 Select parallel-connection Type -> Number of Devices -> Scan Code -> Confirm.



03 The page automatically jumps to the Homepage after parallel setting is successful.

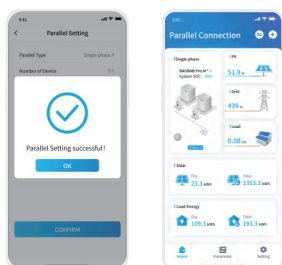

⚠️ Instruction

- Please fill in and double-check the parallel-connection type and number of devices. Otherwise, parallel-connection will ensue.
- If the parallel - connection setting fails, turn off and restart the devices and start the settings all over again.
- If the parallel-connection setting fails, cross-check the following: whether WiFi signal is good, whether the devices are connected to the same WiFi, whether the wiring is correct, or whether the APP operation is correct.

Parameter Setup-Three-Phase AC Output Mode

01 Log in to enter the parallel-connection setting page.

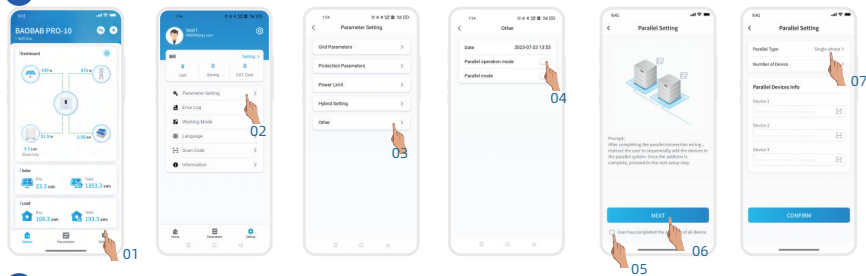

02 Select parallel-connection Type -> Number of Devices -> Scan Code -> Confirm.

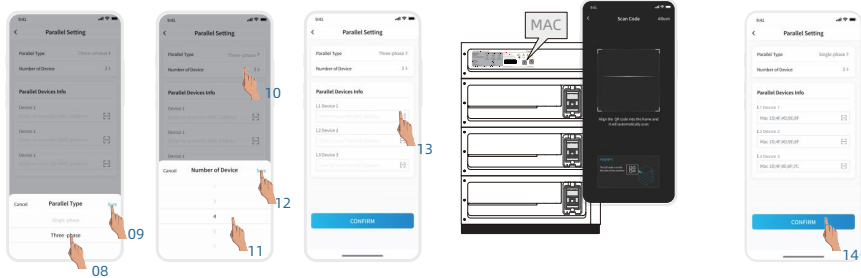

03 The page automatically jumps to the Homepage after parallel setting is successful.

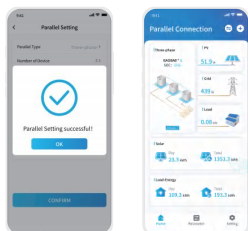

⚠ Instruction

- Please fill in and double-check the parallel-connection type and number of devices. Otherwise, parallel-connection will ensue.
- If the parallel - connection setting fails, turn off and restart the devices and start the settings all over again.
- If the parallel-connection setting fails, cross-check the following: whether WiFi signal is good, whether the devices are connected to the same WiFi, whether the wiring is correct, or whether the APP operation is correct.

End of parallel-connection

01 Turn off all the switches to de-energize the inverter.

02 The LED display and the system will be off.

03 After the parallel setup is complete and the load (EPS) is connected, restart for normal operation.

⚠ Danger

After the light is off, wait at least **10 minutes** for the system to be fully discharged before performing any operation.



⚠ Instruction

For activation sequence, please refer to the power-on process.

Parallel-connection completion

01. Equipment fixation: correct and reliable installation.

02. Cable layout: Cables should be properly and neatly arranged to meet customer requirements.

03. Binding of cable ties: The cable ties are evenly distributed and cut without leaving sharp corners.

04. Installation environment: reasonable installation space, clean and tidy environment, no construction residue.

05. Unused terminals and ports: Install waterproof covers on unused terminals and ports.

9 APP Settings

9.1 APP Download

Method 1: Search for "PotisEdge" in Google App Store or Apple App Store to download and install.

Method 2: Visit the following link with your mobile browser to download:<https://ipotisedge-file.s3.eu-central-1.amazonaws.com/h5/download.html#/pages/download/potisedge>.

Method 3: Scan the QR code on the equipment.

Instruction



App download

APP access may require certain permissions, such as the location permission. When installing the APP or setting up your mobile phone, you need to grant all access to all pop-ups.

Instruction

Please refer to the quick installation manual or download the electronic user manual in PotisEdge for APP operation.

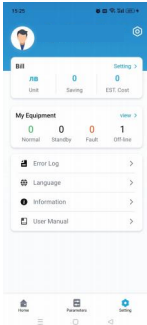

All of the hard copies of the user manual of the company's product families are available on the APP.

10 System Maintenance

Danger

- Observe the User Manual and relevant international, national or regional standards, as well as industry-specific safety rules and practices.
- Power off the equipment before cleaning, electrical connection, grounding reliability check and other maintenance.
- After disconnecting all batteries and AC power supply, wait at least **10 minutes** for the system to be completely powered off before performing any operation.
- Please use special protective equipment and special insulation tools to avoid electric shock or short circuit.
- Do not smoke or use an open flame near the battery.
- Do not use wet rags, water or any solvent to clean bare interfaces or other parts that are electrically conductive.
- Daily maintenance is completed by the customer themselves (such as cleaning and inspection). If there is a malfunction alarm, please contact professional personnel for maintenance.



Warning

- Do not maintain the battery with power on. Check the screw torque and tighten the screw after the battery is powered off.
- After discharge, recharge the battery in time. Otherwise the battery may be damaged due to over-discharge.
- Before moving or rewiring the equipment, cut off the input and output of the power supply. Wait **10 minutes** for the internal energy to be discharged completely. Start maintenance until you have confirmed with a multimeter that no hazardous voltage remains in the DC bus and the components to be repaired.
- Do not connect two or more cables in parallel at the positive and negative interfaces of the battery.
- When making cables, be sure to stay away from the equipment because the chippings may cause damage to either the personnel or the equipment.

10.1 Routine Maintenance

The following operations are performed every six months:

Inspection and cleaning of equipment

- Check whether the heat sink is blocked or dirtied.
- The identification and nameplate on the equipment shall be clear without damage.
- Check whether the cable tie is damaged.
- Whether the surrounding environment meets the installation requirements.

System operational status

- Observe whether the appearance of energy storage system is damaged or deformed.
- Listen whether there is any abnormal sound during the operation of the energy storage system.
- During operation, check whether the system's parameters are set correctly.

Electrical connection

- Check whether the cable connection falls off or is loose.
- Check whether the cable is damaged, and focus on the check on whether there is any cut mark on the surface of the cables that are in contact with the metal surface.
- Check whether the unused DC input terminal, energy storage terminal, COM interface and waterproof cover are locked.
- Check whether the grounding cable is reliably grounded.

10.2 Troubleshooting

If the device does not work properly after you enable it, refer to the table to identify possible causes. At the same time, check whether it is caused by external environment, For example, the temperature and humidity do not meet the requirements or the load is overstressed. If the abovementioned measures don't work, please contact the after-sales service. Please have it professionally repaired.

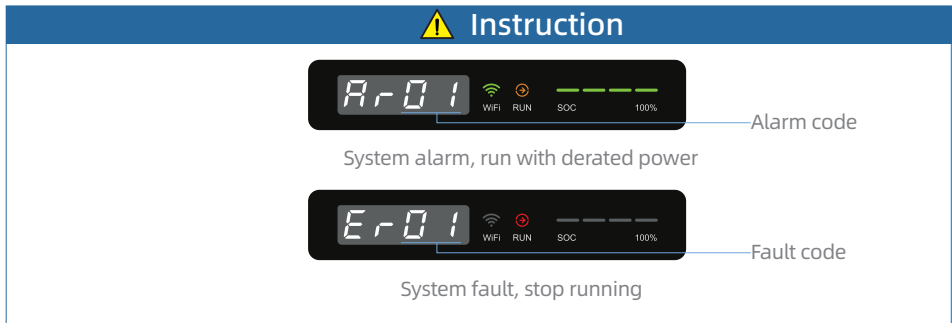

● Alarm method

Alarm code	Meaning	Trigger condition	Recovery condition
A-01	High cell voltage	Warning 3.6V	Restore to 3.4V
A-02	Low cell voltage	Warning 2.7V	Restore to 3.0V
A-03	High battery voltage	Warning 54V	Restore to 52.5V
A-04	Low battery voltage	Warning 43V	Restore to 45V
A-05	High cell voltage difference	Warning 0.5V	Restore to 0.3V
A-06	High cell temperature	Warning 55°C	Restore to 50°C
A-07	Low cell temperature	Warning 4°C	Restore to 6°C
A-08	High cell temperature difference	Reached warning value	—
A-09	High charging current	Warning 105% allowed value	Restore to 100% allowed value
A-10	High discharge current	Warning 105% allowed value	Restore to 100% allowed value
A-11	High MOS temperature	Warning 80°C	Restore to 75°C
A-12	Battery pack offline (≥1 minor failure, all offline serious fault)	Warning one battery pack is offline	Restore all battery packs online
A-13	Loss of communication between BMS and inverter (only serious fault)	No warning fault	—
A-14	Number of parallel machines exceeding faults (only serious fault)	No warning fault	—

● Protection and processing mechanism

Fault code	Meaning	Trigger condition	Recovery condition
Er01	High cell voltage	Protect 3.65V	Restore to 3.4V with discharge current
Er02	Low cell voltage	Protect 2.5V	Restore to 3.0V with discharge current
Er03	High battery voltage	Protect 54.75V	Restore to 51V with charge current
Er04	Low battery voltage	Protect 43V	Restore to 45V with charge current
Er05	High cell voltage difference	Protect, No fault	—
Er06	High cell temperature	Protect 60°C	Restore to 50°C
Er07	Low cell temperature	Protect -10°C	Restore to 0°C
Er08	High cell temperature difference	Reached warning value	—
Er09	High charging current	Protect 110% allowed value	Restore to 100% allowed value
Er10	High discharge current	Protect 110% allowed value	Restore to 100% allowed value
Er11	High MOS temperature	Protect 100°C	Restore to 80°C
Er12	Battery pack offline (≥1 minor failure, all offline serious failure)	Protect all battery packs from 0 disconnection	Restore all battery packs online
Er13	Loss of communication between BMS and inverter (only serious failure)	Protection loss of fault	Restore communication
Er14	Number of parallel machines exceeding faults (only serious fault)	Protection exceed fault	Restore the number of parallel machines
Er15	Controlled fuse blowing protection (only serious fault)	Fuse blown	Replace the fuse
Er16	Pre-charging failure (≥ 1 alarm fault, all dropout protection fault)	Pre-charging voltage insufficient	Restart
Er17	System short circuit overcurrent (only serious fault)	System positive and negative electrodes short circuit	Notify the manufacturer
Er18	MOS short circuit fault (only serious fault)	Battery pack internal short circuit	Notify the manufacturer
Er19	PACK air switch disconnection fault (only serious fault)	PACK air switch off	Connect the PACK air switch and restart

10.3 Emergency Response

In case of equipment abnormality and accident, take correct and effective measures in time to prevent further damage and loss.

01. Overheating:

When the temperature of the battery pack exceeds the upper limit of safe use, the management system will give a warning and ask to stop using it immediately.

02. Leakage:

If battery leakage occurs, evacuate the relevant personnel immediately and notify the technicians to handle the emergency on site. Do not restart the device before troubleshooting. Do not use a system with abnormality.

03. Short circuit:

If the product is short-circuited for various reasons, immediately evacuate the relevant personnel, cut off the power supply and the equipment (if possible), disconnect the battery from the equipment, and notify the technical personnel for repair and troubleshooting. The equipment and devices that have been severely short-circuited must be rigidly tested by the manufacturer before deciding whether they can continue to be used.

04. Collision:

For various reasons, if the equipment is impacted, deformed or pierced by foreign objects, the power cable of the equipment should be disconnected immediately. Notify professional technicians to be present for handling. In case of special circumstances, wearing necessary protective equipment before disassembly.

05. Fire:

Step 1: Evacuate the site personnel to an isolation area designated for safety purpose, and call firefighters.

Step 2: Under the precondition of ensuring personal safety, carry out the following operations if conditions permit:

- If the harness smokes and catches fire, use a carbon dioxide or dry powder fire extinguisher to put out the fire.
- If the energy storage battery is on fire, use a high-pressure water gun at a distance to put out the fire.
- If smoke is inhaled, evacuate and seek medical care ASAP.

Step 3: Inform the equipment manufacturer to obtain further treatment opinions.

06. Flooding

Step 1: Check whether the equipment is powered on or not, evacuate the site personnel to an isolation area designated for safety purpose.

Step 2: Inform the equipment supplier to carry out maintenance after the flood has faded.

Step 3: Do not start the system before the manufacturer confirms the system is safe to use.

10.3 Emergency Response

07. Other accidents:

When repairing or removing the equipment due to other accidents, disconnect the battery circuit first to avoid electrocution. Do not disassembly until you ensure that no short-circuit will occur. Check to confirm that no secondary damage will arise from collision, fall, inversion or other reasons.



Danger

- If any condition that may wreak havoc on the battery or equipment looms, please contact the after-sales personnel. Do not disassemble it without permission.
- If the copper wire inside the conductive wire is found exposed, it must not be touched. High voltage is fatal . Please contact the after-sales personnel. Do not disassemble it without permission.
- In case of other emergencies, please contact the after-sales personnel without delay for guide, or wait for the after-sales personnel to operate on site.

10.4 Battery Recycling

iPotisEdge does not recycle batteries. Please dispose of waste batteries according to local laws and regulations. Please do not dispose of batteries as domestic waste. Improper disposal of the battery may cause environmental pollution or explosion.

If there is no local recycling agency, customers are advised to contact the nearest national or regional recycling agency for disposal.

Warning

- If the battery leaks or is damaged, please contact the technical support personnel or the battery recycling company for the disposal.
- When the battery is out of its service life, please contact the battery recycling company for the disposal.
- Avoid exposing used batteries to high temperatures or direct sunlight.
- Avoid exposing used batteries to high humidity or corrosive environments.
- Secondary use of faulty batteries is prohibited. Contact the battery recycling companies ASAP to avoid environmental pollution.

Recycling process:

Step 1 Contact the nearest recycling agency.

Step 2 The recycling agency assesses the cost of recycling.

step 3 The recycling agency carries out recycling, which can be done in two ways:

On-the-spot recycling: The recycling agencies go to the spot where the Li-ion batteries are used to recycle the spent batteries. The service charge will be assessed according to the factors such as distance or transport cost.

Centralized recycling: Scrap Li-ion batteries are aggregated to a designated place to be recycled by the recycling agency.

11 After-sales Service

iPotisEdge offers a full range of technical supports and after-sales services. The free warranty is subject to the contract or warranty agreement. The following conditions are not within the scope of the free warranty services provided by the company:

- Damage to the system or consequent failure due to operation not in accordance with the instruction manual.
- Damage or malfunction caused by wiring and power supply not in accordance with the relevant electrical safety regulations, or due to poor site environment.
- Damage to the system or malfunction caused by the user's unauthorized remodeling.
- Damage or failure caused by force majeure such as typhoon, earthquake, flood, fire, or harsh environment (high temperature, low temperature, high humidity, acid rain, etc.).
- Failure of the user to maintain the initial state of device malfunction, and failure to notify the manufacturer in a timely manner and deal with the problem on their own, making it hard to identify the cause of the failure.

Should you have any questions about the equipment, please contact us. In order to provide you with faster and better services, please provide the following information:

- | | |
|---------------------|---------------------------------------|
| (1) Equipment model | (2) Equipment serial number (SN code) |
| (3) Fault code/name | (4) Brief description of the fault |



© 2023 iPotisEdge Co., Ltd. All rights reserved.

JK Energy and iPotisEdge , PotisEdge are trademarks of iPotisEdge Co., Ltd.
All other trademarks are owned by iPotisEdge Co., Ltd or their respective owners.

For more information about iPotisEdge ESS Solutions please visit: ipotisedge.com

Write us an e-mail: sales@ipotisedge.com

Or follow us:     