

S M A R T E N E R G Y L I G H T S U P T H E G R E E N E A R T H

# THREE-PHASE ESS INVERTER

## USER MANUAL

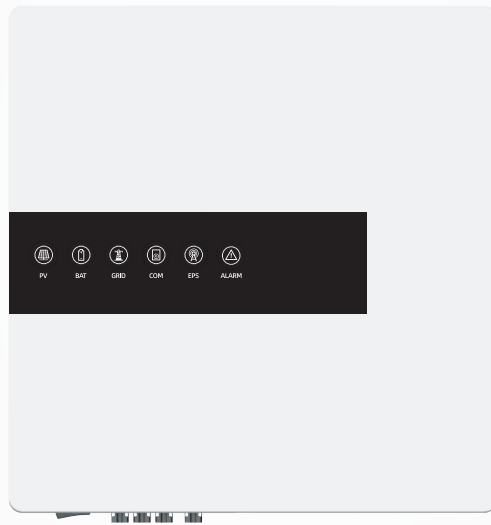

## Modification Record

Modify the instructions for each document update. The latest version of the document contains updated content from all previous versions.

Issue V1.0 (2022-08-07)      This issue is the first official release.

## Copyright Statement

This document and the information contained therein belong to "iPotisEdge Co., Ltd". Without written permission from the company, this document or the information contained therein shall not be disclosed or disseminated to any third party organization or individual.

## Trademark Licensing

The trademark used in this document belong to iPotisEdge Co., Ltd. All other trademarks and registered trademarks mentioned in this document are the property of their respective holders.

## Declaration

The purchase of products, services or features are stipulated by the commercial contract made between iPotisEdge Co., Ltd. and the customer. All or part of the products, services, or features described in this document may not be within the purchase scope or the usage scope.

Unless otherwise agreed in the contract, iPotisEdge Co., Ltd. does not make any warranties, guarantees or representations of any kind, either express or implied of this document.

The contents of this document is subject to change without notice. Unless otherwise agreed, this manual is only for guidance, and all statements, information and recommendations in this manual do not constitute a warranty of any kind, express or implied.

## Purpose

This document mainly describes the product introduction, application scenarios, installation and commissioning, system maintenance and technical specifications of Inverter :

**IPT-5K-S      IPT-6K-S      IPT-8K-S      IPT-10K-S**  
**IPT-5K-SH    IPT-6K-SH    IPT-8K-SH    IPT-10K-SH**

## Intended Audience

This document is intended for:

- Sales Engineers
- System Engineers
- Technical Support Engineers
- End Users (The user is not allowed to operate the items marked with the qualification certificate without permission.)

## Symbol Definition

In order to ensure personals and property safety and better use when the user installs the product, this manual clarifies the relevant information and emphasizes it with the standard symbols. The following symbols are used in this product. Please read them carefully to make better use of this manual.

### **Danger**

Indicates a hazard with a high level of risk,If not avoided, will result in death or serious injury.

### **Warning**

Indicates a hazard with a medium level of risk, If not avoided, could result in death or serious injury.

### **Caution**

Indicates a hazard with a low level of risk,If not voided, could result in minor or moderate injury.

### **Note**

Supplements the important information in the main text.

NOTE is used to address information not related to personal injury, equipment damage, and environment deterioration.

## Branding Definitions



Caution! Risk of electric shock



Do not place near flammable materials



Watch out



Do not short circuit the battery



Be careful of fire



Do not install or disassemble by non-professionals



High surface temperature



Install the product out of the reach of children



After power failure, there is a delay in discharging the components.  
Please wait for 10 minutes until the equipment is completely discharged.



It is forbidden to discard this product at will,  
and it shall be sent to the designated recycling place.



Do not dispose of this product with residential waste.



Recyclable



Read the instructions carefully before  
installation and use



CE certification

## Definition of Abbreviation

Short Name	Full Name	Short Name	Full Name
FPC	Flexible Printed Circuit	SOC	State Of Charge
BMS	Battery Management System	BM	Battery Module
BMU	Battery Management Unit	PCS	Power Conversion System
BOL	Begin Of Life	EOL	End Of Life
Bus-bar	Current Connection Between Cells	OCV	Open Circuit Voltage
CAN	Controller Area Network	S/G	Switch Gear
EPS	Emergency Power Supply		

# CONTENT

<b>1 Safety Notice.....</b>	
1.1 Personal Safety.....	
1.2 Electrical Safety.....	
1.3 Battery Safety.....	
1.4 Environmental Requirements.....	
1.5 Mechanical Safety.....	
<b>2. Product Introduction .....</b>	
2.1 Overview.....	
2.2 Product Appearance.....	
2.3 Model Definition .....	
<b>3. Installation .....</b>	
3.1 Packing List.....	
3.2 Selecting the Mounting Location .....	
3.3 Mounting.....	
<b>4. Electrical Connection.....</b>	
4.1 Grounding.....	
4.2 GRID/BACKUP Connection.....	
4.3 Battery Connection .....	
4.4 PV Connection .....	
4.5 Meter/CT Connection .....	
4.6 Communication Connection .....	
<b>5. System Operation.....</b>	
5.1 Inverter Working Mode.....	
5.2 Startup/Shutdown Procedure.....	
<b>6. Commissioning .....</b>	
6.1 Inspection .....	
6.2 Commissioning Procedure.....	

# CONTENT

<b>7. User Interface</b> .....	
7.1 LED .....	
7.2 App Setting Guide .....	
<b>8. Maintenance</b> .....	
8.1 Routine Maintenance .....	
8.2 Inverter Troubleshooting .....	
8.3 Removing the Inverter .....	
<b>9. Technical Specifications</b> .....	

# 1 Safety Notice

## Declarations

- Before transporting, storing, installing, operating, using or maintaining the equipment, please read this manual first, operate in strict accordance with the contents of the manual, and follow the signs on the equipment and all safety precautions in the manual.
- In this manual, "equipment" and "product" refer to the products, software, parts, spare parts or services related to this manual; "Company" means the manufacturer (producer), seller or service provider of the Equipment; "You" means the person who transports, stores, installs, operates, uses, or maintains the Equipment.
- The "Danger", "Warning", "Caution" and "Notice" in the manual do not represent all the safety matters that should be observed. You should also comply with relevant international, national or regional standards and industry practices.
- The company shall not be liable for any violation of safety operation requirements or safety standards for design, production and use of equipment.
- This equipment should be used in an environment that meets the requirements of the design specifications, otherwise it may cause equipment failure, abnormal equipment function or component damage, which is not within the scope of equipment quality assurance.
- If the equipment is used in an environment that does not meet the requirements of the design specifications, it may cause personal injury, property loss, etc., and the company will not be liable for compensation.
- All operations such as transportation, storage, installation, operation, use and maintenance shall comply with applicable laws, regulations, standards and specifications.
- Do not perform reverse engineering, decompilation, disassembly, adaptation, implantation, or other derivative operations on the equipment software. Do not study the internal implementation logic of the equipment, obtain the source code of the equipment software, violate intellectual property rights, or disclose any of the performance test results of the equipment software.

## **Our Company shall not be liable for any of the following circumstances or the consequences there of:**

- Equipment damage caused by force majeure, such as earthquake, flood, volcanic eruption, mudslide, lightning strike, fire, war, armed conflict, typhoon, hurricane, tornado, extreme weather, etc.;  
Not operating under the service conditions required by the product manual;
- Failure to operate according to the operating instructions and safety warnings in the product and documents;
- Unauthorized disassembly, alteration of products or modification of software codes;
- Damage caused by failure to store the product in accordance with the product documentation requirements;
- The installation and use environment does not conform to relevant international, national or regional standards;
- Equipment installation and use by unqualified personnel;
- Your self-provided materials and tools do not meet the requirements of local laws, regulations and relevant standards;
- Damage caused by transportation by you or a third party entrusted by you;
- Damage caused by your or a third party's negligence, intent, gross negligence, improper operation or not caused by iPotisEdge.

## 1.1 Personal Safety

### Danger

- Ensure that the power is off during installation. It is forbidden to install, disassemble and connect the machine with power on. Installation with power on may produce electric arc, electric spark or fire and explosion, resulting in fire or personal injury in serious cases.
- When the equipment is electrified, please operate it correctly. Otherwise, fire, electric shock or explosion may occur, resulting in casualties or property damage.
- It is strictly forbidden to wear watches, bracelets, bangles, rings, necklaces and other easily conductive objects during operation, so as to prevent electric shock.
- During operation, use special protective equipment, such as protective clothing, insulating shoes, goggles, safety helmet, insulating gloves. Meanwhile, use dedicated insulation tools to avoid electric shock or short circuit.
- The insulation withstanding voltage level must comply with local laws, regulations, standards and specifications.

### Warning

- Do not stop equipment protection devices and pay attention to the warnings, cautions, and precautions in manuals and equipment.
- During operation, if any fault that may cause personal injury or equipment damage is found, stop the operation immediately, report the case to the person in charge, and take effective protective measures.
- Do not power on the equipment before it is installed or confirmed by professionals.
- Do not touch the power supply equipment directly or with conductors such as damp objects.
- Before touching any conductor surface or terminal, measure the voltage at the contact point to confirm that there is no risk of electric shock.
- During the operation of the device, the casing temperature is high and there is a risk of burns. Please do not touch it.
- In case of fire, evacuate the building or equipment area and press the fire alarm bell, or call the fire alarm telephone. In any case, re-entry into the area of the burning building or equipment is strictly prohibited.

## Requirements for installation operators:

- The personnel responsible for the installation and maintenance of the equipment must receive adequate training, master the correct methods of operation, and understand the safety precautions and local standards of the country/region.

**Professional:** a person who is familiar with the principle and structure of the equipment, has experience in training or operating the equipment, and can understand the potential sources and levels of hazards during the installation, operation and maintenance of the equipment.

**Trained person:** a person who has received appropriate technical and safety training and has the necessary experience to be aware of the hazards that may be brought to him during an operation and to take measures to minimize the hazards to himself and other personnel.

- Only qualified professionals or trained personnel are allowed to install, operate and maintain, remove safety devices and overhaul equipment.
- Personnel who will perform special tasks such as electrical operation, climbing operation and special equipment operation must have the relevant qualification required by the local country/region.
- Only authorized professionals are allowed to replace the equipment or parts (including software).
- During installation or maintenance, only those who need to operate the equipment are allowed to access the equipment.

## 1.2 Electrical Safety

### Danger

- Before making electrical connections, make sure that the equipment is not damaged, or it may cause electric shock or fire.
- Non-standard and incorrect operation may cause accidents such as fire or electric shock.
- During the operation, prevent foreign matters from entering the equipment, otherwise short circuit, equipment damage, load power derating, power failure or personal injury may occur.
- When installing the equipment, connect the protective ground wire first; when removing the equipment, remove the protective ground wire last.

### Warning

- The product must be installed, operated and maintained according to the steps in the manual. Do not modify, add or change the equipment without authorization, and do not change the installation sequence without authorization.
- It is necessary to obtain permission from the grid department of the country or region before connecting to the grid.
- Before installing and removing the power cable, disconnect the equipment itself and its front and rear switches.
- Approval from the national or regional electricity authority is required for grid connection and operation.
- Before operating the equipment, ensure that the tools used meet the requirements and are registered; after the operation, collect all of the tools to prevent them from being left inside the equipment.
- Before installing the power cable, make sure that the cable label is correct and the cable terminal is insulated.
- When installing the equipment, it is necessary to select a torque tool with appropriate range to tighten the screws. When tightening with a wrench, make sure that the wrench is not skewed and the torque error does not exceed 10% of the specified value. Screws shall be fixed with torque tools and double checked with red and blue markings.
- After installation, ensure that all electrical components, protective shells, insulating sleeves and other devices are in place to avoid the risk of electric shock.
- If the equipment has multiple inputs, disconnect all inputs, and operate the equipment after it is completely powered off.
- Before maintaining a downstream electrical or power distribution device, turn off the output switch on the power supply equipment.

## Warning

- During maintenance, hang a "Do not switch on" sign on the upstream and downstream switches or circuit breakers as well as a warning sign to prevent accidental connection. The equipment can be powered on only after troubleshooting is complete.
- If it is necessary to cut off the power for maintenance, take the following safety measures: Power-off > Check the electricity > Install the grounding wire > Hang the warning sign and set up the barrier.
- Non-professionals are not allowed to open the inside of the equipment.
- Please regularly check the equipment connection terminals, ensuring that the screws are securely tightened.
- Please regularly check whether the equipment cable is damaged. If necessary, it must be replaced by professionals to avoid risks.
- Do not artificially alter, damage or block the signs and nameplates on the equipment, and promptly replace the signs that have worn out.
- Do not use solvents such as water, alcohol or oil to clean the electrical components inside and outside the equipment.
- **Installers need to follow local regulations, installation standards, and network requirements.**

## 1.3 Battery Safety

### Danger

- Do not short circuit the positive and negative poles of the battery, otherwise it will cause short circuit of the battery. (A short circuit in the battery can produce a high current and release a large amount of energy, causing the battery to leak, smoke, release flammable gases, run away from heat, catch fire, or explode.)
- It is strictly prohibited to maintain the battery with power on, otherwise it will cause short circuit of the battery.
- It is strictly forbidden to expose the battery to high temperature or around heating sources, such as high temperature sunshine, fire source, transformer, heater, etc. (Battery overheating may cause leakage, smoke, release of flammable gases, thermal runaway, fire, or explosion.)
- Do not touch battery terminals with other metal objects, which may cause heating or electrolyte leakage.
- Please obtain the batteries recommended by the manufacturer through regular channels. Incorrect use or replacement of batteries may cause fire and explosion.
- The battery is a closed system and will not release gases under normal operation. In case of extreme cases, such as burning, pinching, squeezing, lightning strike, overcharging or other severe conditions that may lead to battery thermal runaway, the battery may be damaged or abnormal chemical reaction may occur inside the battery, resulting in electrolyte leakage or production of gases such as CO and H<sub>2</sub>. To avoid burning or corrosion of the equipment, ensure that the flammable gases are properly exhasusted.
- Non-professionals are advised not to approach in case of battery accidents (the electrolyte is toxic and volatile). Please contact a professional immediately for assistance.
- When battery accidents occur, professionals should wear goggles, rubber gloves, gas masks, protective clothing, and other necessary safety gear. They should promptly deenergize the equipment and remove the leaking battery. At the same time, contact a technical engineer or the after-sales department for further handling.

### Warning

- Before storage, transportation and removing the package, ensure that the outer packing is intact, and the battery is placed correctly according to the mark of the packing box. Do not place the battery upside down, on the side, vertically or obliquely. Stack the battery in accordance with the stacking requirements on the outer package, so as to avoid any damage to the battery caused by crash or falling.
- Install batteries in areas far away from liquids. Do not install them in places prone to water leakage, such as air conditioning outlets, vents, machine room outlet windows, water pipes, etc. Ensure that no liquid enters the equipment to prevent system failure or short circuit.



## Warning

- Tighten the fastening screws of the copper bar or cable according to the torque specified in the document, and regularly check whether they are tightened and whether there is rust, corrosion or other abnormalities. Otherwise, the false connection of screws will lead to excessive connection voltage drop, or even burn the battery when the current is high.
- After the battery is discharged, charge them in time to avoid damage due to over-discharge.

## 1.4 Environmental Requirements

### Danger

- The installation and usage environment shall comply with local laws and regulations and relevant international, national and regional standards for lithium-ion products.
- Do not place the equipment in an environment with flammable and explosive gas or smoke, and any operation is prohibited in such an environment.
- Do not place the equipment in a humid environment near the water source and chemical industry, and to carry out any operation in such environment.
- Do not store inflammable and explosive articles in the equipment area.  
Do not place equipment near sources of heat or fire, such as fireworks, candles, heaters, or other heating equipment. Equipment heating may cause damage to the equipment or fire.
- Do not install the equipment in moving scenes such as ships, trains and automobiles.
- Do not install the equipment in an environment with metal conductive dust and magnetic dust.
- Do not install the equipment in an environment with direct sunlight, dust, smoke, volatile gas, corrosive gas, infrared radiation, organic solvent or high salt content.

### Warning

- The equipment shall be installed in the area far away from the liquid. It is strictly prohibited to install it under the water pipe, air outlet and other places where condensation is easy to occur.
- Do not install the equipment under the air conditioning port, ventilation port, machine room outlet window and other places where water is easy to leak, so as to prevent liquid from entering the equipment and causing equipment failure or short circuit.
- When the equipment is running, do not cover the vent, cooling system or other objects to prevent high temperature damage to the equipment or fire.
- Keep the installation location out of the reach of children and far away from the daily working and living areas, including but not limited to the following: studio, bedroom, living room, music room, kitchen, study, game room, home theater, sun room, toilet, shower room, laundry room and attic.
- Do not install in closed, unventilated places without proper fire fighting facilities or difficult for firefighters to reach.
- When the equipment is running, the temperature of the chassis and heat sink will be relatively high. Do not install it in a position that is easily accessible.
- Do not install, use and operate outdoor equipment and cables in bad weather such as thunder and lightning, rain, snow and gale above Grade 6. (Including but not limited to handling equipment, operating equipment and cables, plugging and unplugging signal interfaces connected to the outdoors, working at heights, outdoor installation, door opening, etc.)

## Caution

- Garage installation should be far away from the direction and parking position of the vehicle. It is recommended to install it on the wall higher than the bumper to avoid accidental collision.
- Do not install it in the areas that is easy to be flooded. For areas prone to natural disasters, such as floods, debris flows, earthquakes and typhoons, take corresponding preventive measures for installation.
- Do not install the equipment outdoors in salt-damaged areas to avoid corrosion. Salt-damaged area refers to the area within 500m from the coast or affected by sea breeze. The area affected by the sea breeze varies according to the meteorological conditions (e.g. Typhoon, monsoon) or the terrain (with dams, hills).
- Please install it in a sheltered place or build a sunshade to avoid direct sunlight or rain.
- Please install it on a solid ground, without rubber soil, soft soil or difficult to sink. Do not select low-lying areas that are easy to accumulate water and snow. The water level of the station should be higher than the highest water level in the history of the area.
- If it is installed in a place with lush vegetation, in addition to routine weeding, it is necessary to harden the ground under the equipment, such as laying cement, stones, etc.
- Before installation, operation and maintenance, it is necessary to clean up the water, ice and snow or other debris around and on the top.
- Before installation, please ensure that the installation surface is solid and meets the requirements of equipment bearing.
- After installation, remove the packaging materials such as cartons, foam, plastic, cable ties, etc. from the equipment area.

## 1.5 Mechanical Safety

### Danger

When working at heights, wear safety helmet, safety belt or waist rope and fasten it to a solid structure. Do not hang on a moving and unstable object or metal objects with sharp edges and corners, so as to prevent the hook from slipping and falling.

### Warning

- Do not use tools with scars, unqualified inspection or beyond the validity period to ensure that the tools are firm.
- Do not drill holes in the equipment. Drilling will damage the tightness, electromagnetic shielding performance, internal devices and cables of the equipment, and the metal chips generated by drilling will enter the equipment and cause a short circuit of the circuit board.

### Caution

- Paint scratches during equipment transportation and installation must be repaired in time. Do not expose the scratched parts for a long time.
- Do not conduct arc welding, cutting and other operations on the equipment without the written permission of the company.
- Do not install other devices on top of the equipment without the written permission of the company.
- When working in the space above the top of the equipment, take measures to protect the equipment from damage.
- Please prepare complete tools, use the corresponding tools correctly, and master the correct use of tools.

#### ● Notice for drilling

- Obtain consent from the client and the contractor before drilling holes.
- Wear safety equipment such as goggles and protective gloves when drilling.
- When drilling, please avoid the embedded pipes or lines to avoid short circuit or other dangers.
- When drilling, protect the equipment from debris and clean up the debris in time after drilling.

## ● Instructions for carrying heavy objects

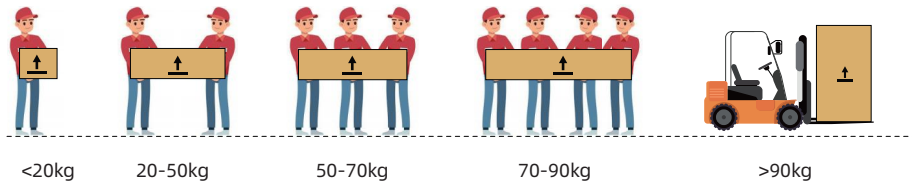

- When carrying heavy objects, please assess your own load-bearing capacity to avoid being crushed or sprained by heavy objects.
- When many people carry heavy objects at the same time, it is necessary to consider the height and other conditions, reasonable personnel collocation and division of labor to ensure the balanced distribution of weight.
- Please lift the weight slowly, or place the weight on a half-waist-high workbench or a suitable place, and adjust the position of the palm before lifting.
- Heavy objects must be carried with balanced and steady force; the moving speed shall be uniform and low; the positioning shall be smooth and slow to avoid any impact or falling to scratch the surface of the equipment or damage the components and cables of the equipment.
- When carrying heavy objects, pay special attention to the workbench, slope, stairs and some places that are easy to slip. When carrying heavy objects through the threshold, make sure that the door is wide enough for the equipment to pass through, so as to prevent bruising or scratching fingers.
- When the forklift is used for handling, the fork of the forklift must be in the middle position to prevent overturning. Before moving, please fasten the equipment to the forklift with ropes; when moving, assign dedicated personnel to take care of it.
- During transportation, fix the equipment firmly to minimize bumps and inclines.

## ● Notice for use of ladder

- Use wooden ladders or insulated ladders when performing live-line operations at heights.
- Platform ladder with protective fence is preferred for climbing operation, and straight ladder is not recommended.
- Before using the ladder, please confirm that it is intact and its load bearing capacity meets the requirements. Do not overload it.
- Place the ladder in a stable place and have it held tightly during operation.
- When climbing the ladder, keep your body steady and your center of gravity within the ladder frame, so as to reduce the danger and ensure safety.
- When using the ladder, the pull rope must be firm.
- If a straight ladder is used, the inclination of the ladder should be 75 °, which can be measured with an angle square.

- If a straight ladder is used, place the wide foot of the ladder down or protect the bottom of the ladder from slipping.
- If a straight ladder is used, the maximum height of the feet should not exceed the fourth step from the top to the bottom of the ladder.
- If a straight ladder is used to climb the platform, the vertical height of the ladder above the platform shall be at least 1 meter.

### ● **Notice for aerial work**

- Work carried out above 2 meters from the ground belongs to high-altitude work, and a supervisor must be set up for high-altitude work.
- Operators must receive relevant training and obtain relevant qualification certificates before they can work at heights.
- Do not work at heights when the steel pipe is not dry or other dangerous situations may occur. After the above conditions no longer exist, the person in charge of safety and relevant technical personnel must check the involved equipment and confirm the safety before operation.
- Set a restricted area and prominent signs for working at heights to warn away irrelevant personnel from entering.
- Set up guardrails and signs at the edges and openings of high-altitude operation to prevent falls.
- Do not pile up scaffolds, springboards or other sundries on the ground below the aerial work area. Personnel on the ground are strictly prohibited to stay or pass directly below the high-altitude operation area.
- Carry operating instruments and tools to prevent equipment damage or personal injury caused by falling tools.
- During high-altitude operation, do not throw objects from the height to the ground or vice versa. Transport objects by sling, hanging basket, overhead vehicle or crane.
- Do not operate the upper and lower layers simultaneously. If it is unavoidable, take a special protective shed between the upper and lower layers or take other protective measures. Do not stack tools or materials on the upper layer.
- After finishing the work, dismantle the scaffolds from top to bottom. Do not dismantle the upper and lower layers at the same time. When dismantling a part, ensure the other parts do not collapse.
- Do not play or eat when working at heights.
- The personnel working at heights shall operate in strict accordance with the safety regulations, and the Company shall not be responsible for any accident caused by violation of the high-altitude safety operation regulations.

## 2. Product Introduction

### 2.1 Overview

#### ESS Inverter

The ESS inverters are high-quality inverter which can convert solar energy to AC energy and store energy into battery.

The inverter can be used to optimize self consumption, store in the battery for future use or feed into public grid. Work mode depends on PV energy and user's preference. It can provide power for emergency

use during the grid lost by using the energy from battery and inverter (generated from PV).

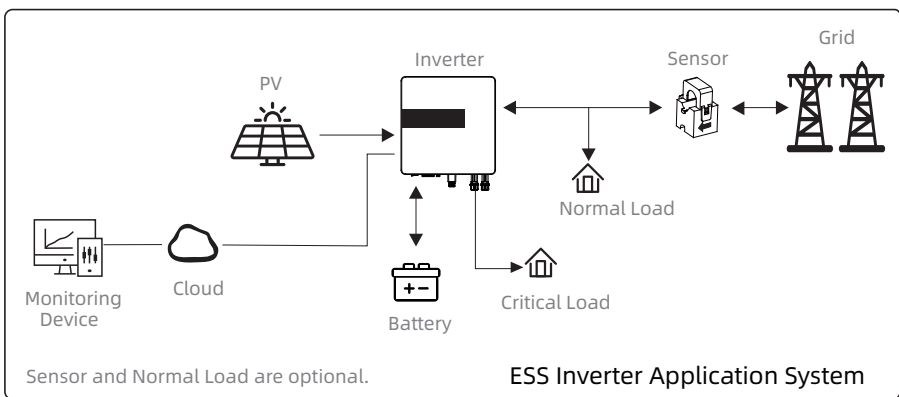

## 2.2 Product Appearance

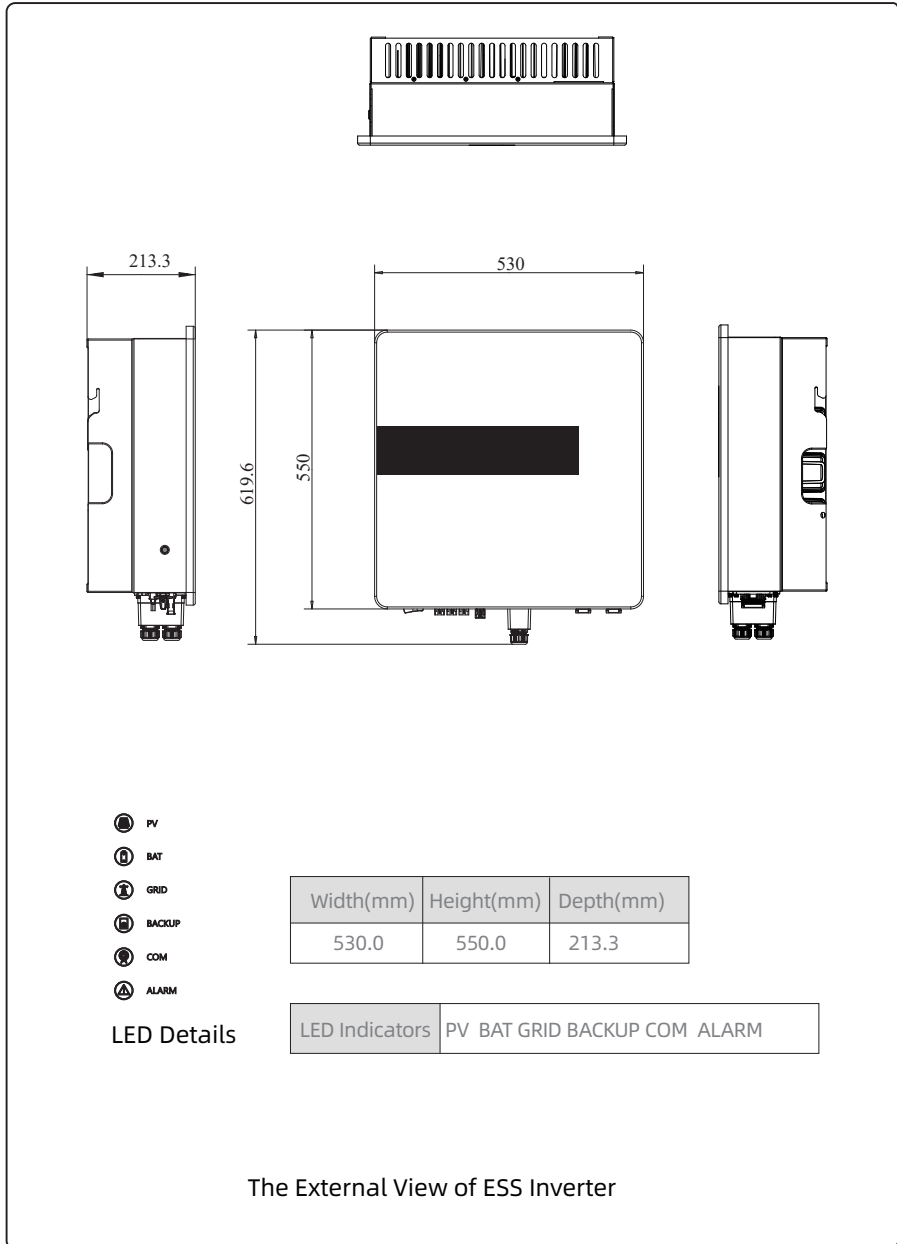

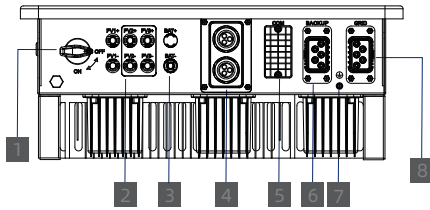

The bottom view of ESS inverter

1. PV Switch
2. PV Input Terminals
3. Battery Connect Terminals
4. COM1 Ports  
(RS485, BMS, DRMs/RCR, CT, NTC/DI/DO, RSD/RMO, PARA)
5. COM Port  
(WIFI/LAN)
6. BACKUP Output Terminal
7. Grounding Terminal
8. GRID Output Terminal

## 2.3 Model Definition

The letters in the product model have the specific informations.  
( Take 5K as example.)

5K

Power(5000W)

# 3. Installation

## 3.1 Packing List

After unpacking, please check the following packing list carefully for any damage or missing parts. If any damage or missing parts occurs, contact the supplier for help.

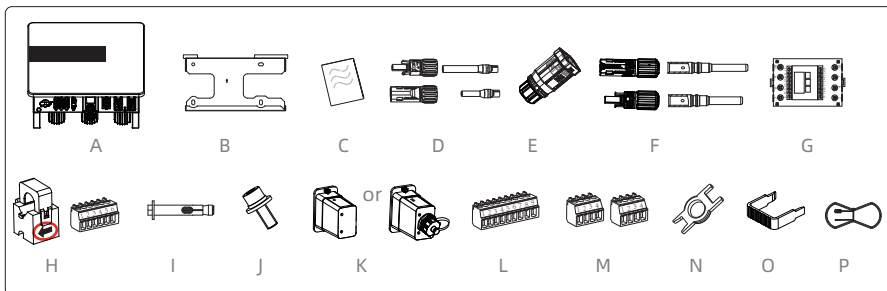

Number	Quantity	Description
A	1	Inverter
B	1	Mounting bracket
C	1	File package
D	2/2 for 5/6K; 3/3 for 8/10K	PV terminal connector group (PV+/PV-)
E	2	GRID/BACKUP connector
F	1/1	Battery terminal connector group (BAT+/BAT-)
G	1	Meter (Optional)
H	1	CT pack (3pcs CT + 1pcs 6-Pin terminal)
I	4	M10 Expansion screws
J	1	M6 Security screw
K	1	WIFI/LAN module (Optional)
L	1	9-Pin terminal
M	2	4-Pin terminal
N	1	Removal tool for PV/BAT connector
O	1	Removal tool for GRID/BACKUP connector
P	1	Battery Temperature sensor (Optional)

## 3.2 Selecting the Mounting Location

### 3.2.1 Installation Environment Requirements

- The storage inverter protection class is IP65 and can be mounted indoors or outdoors.
- To ensure optimum operation and long service life, the ambient temperature must be below 50°C.
- Do not install the inverter in a rest area since it will cause noise during operation.
- The inverter carrier must be fire-proof. Do not mount the inverter on flammable building materials.
- Ensure that the wall meets the requirements of the inverter installation.
- Product label and warning symbols shall be clear to read after installation.
- The installation height should be reasonable and make sure it is easy to operate and view the display.
- Please avoid direct sunlight, rain exposure, snow cover.

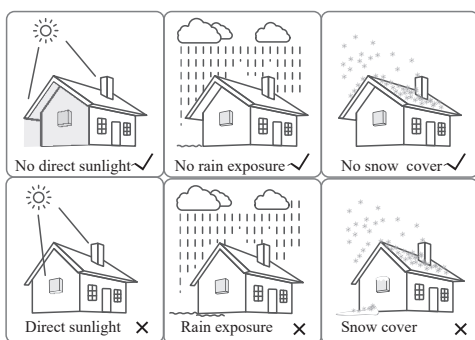

### 3.2.2 Mounting Requirements

Mount the inverter vertically or tilted backward by max 15°. The device can not be installed with a wrong mode and the connection area must point downward.

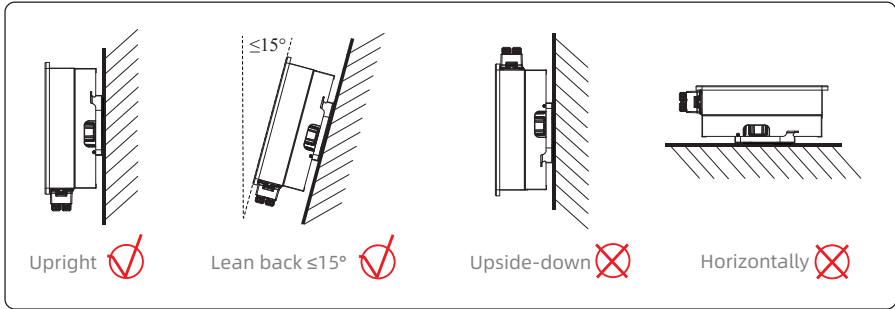

### 3.2.3 Installation Space Requirements

To ensure the inverter operate normally, there are requirements on available spaces of the inverter, e.g. to keep enough clearance. Refer to the following figures.

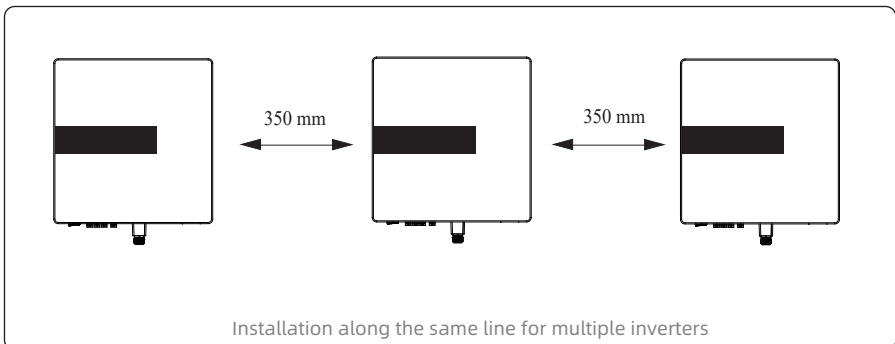
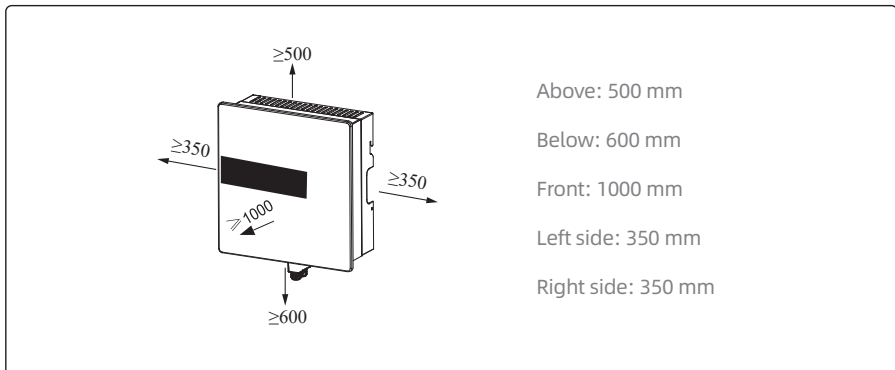

### 3.3 Mounting

Before mounting the inverter, you have to prepare expansion screws and security screw.

#### Step 1. Install the mounting bracket

1. Use a level ruler to mark the position of the 4 holes on the wall. Refer to Figure a. And drill 4 holes, 12mm in diameter and 60mm in depth. Refer to Figure b.
2. Knock the expansion screw kit into the hole with a hammer. Refer to Figure c.

Note:

Do not remove the nut unit in this step.  
Before taping the expansion screw kit into the hole, you need to screw the bolt out 1-2 turns.

3. After fastening 4 bolts, the expansion bolts are tight and not loose, and then unscrew the threaded bolts, gaskets. Refer to Figure c.
4. Install and fix the mounting bracket on the wall. Refer to Figure d.

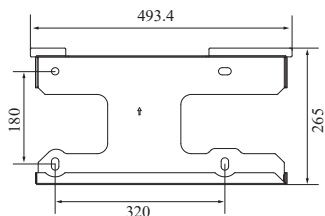

Unit: mm

#### Step 2. Install the inverter on the mounting bracket.

Then lock the inverter using the security screw. Refer to Figure e, Figure f.

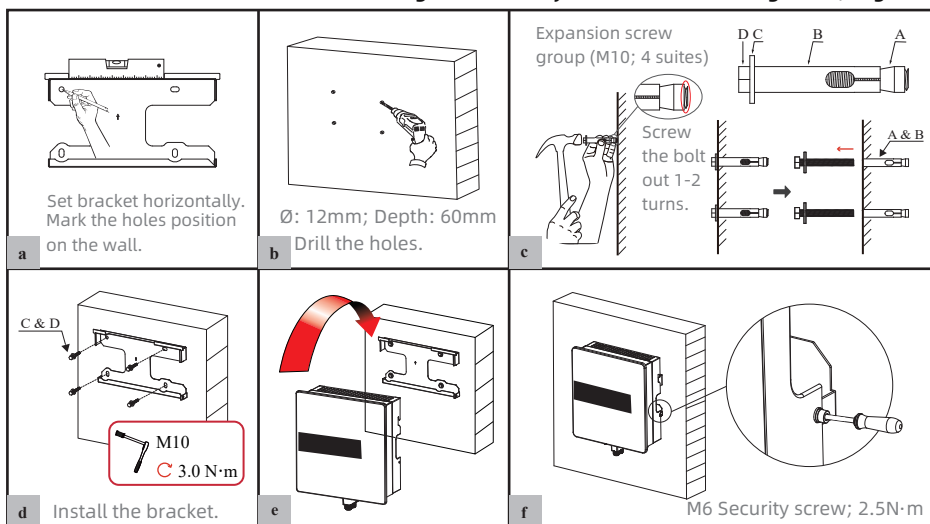

#### Danger

Before drilling the hole on the wall, ensure not to drill on the electric wire and/or water pipe inside the wall.

#### Warning

To prevent potential damages and injuries from inverter falling down, please hang the inverter on the bracket. Do not loosen grip unless it is confirmed that the inverter is well mounted.

## 4. Electrical Connection

This chapter shows the detailed connection of three phase ESS inverter. The following illustration only uses the ESS inverters as an example.

### Danger

Ensure that the inverter and all cables to be installed have been completely powered off during the whole process of installation and connection. Otherwise, fatal injury could be caused by the high voltage.

### Three phase ESS inverter system connection diagram: Connection mode for whole-house load

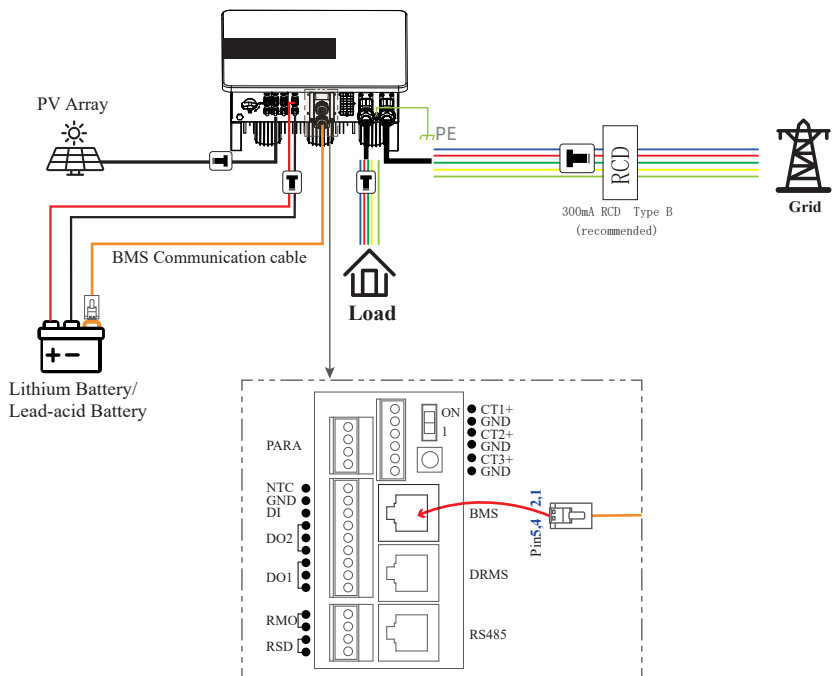

Note:

1. BMS communication connection is only for lithium battery.

2. About breakers:





DC breaker on PV side  $\geq 40A$  (2P) ;

DC breaker on battery side  $\geq 40A$ (2P);

AC breaker on load side  $\geq 32A$  (4P);

AC breaker on grid side  $\geq 63A$  (4P) ;

The specifications of main breaker and normal load breaker depend on household loads.

COM	
L1	
L2	
L3/Positive	
Negative	
N	
PE	
Breaker	



# Parallel connection mode-Scheme A (N=2)

- COM —
- L1 —
- L2 —
- L3/Positive —
- Negative —
- N —
- PE —
- Breaker

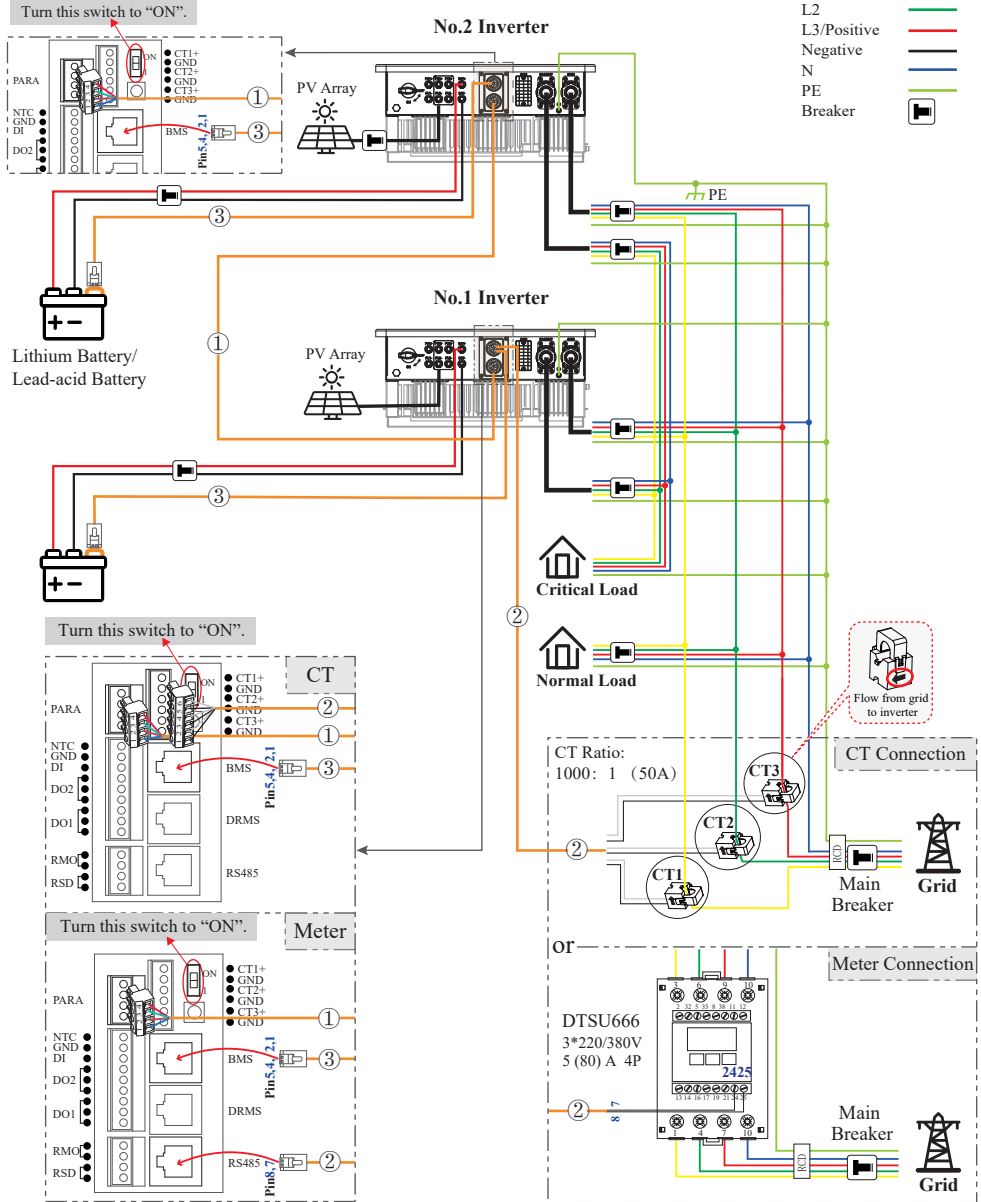

- ① Parallel communication connection
- ② CT/Meter communication connection
- ③ BMS communication connection

\* These communication cables can be connected to any inverter, but they must be inserted into the same inverter and we call this inverter No. 1 inverter.

**Note for Scheme A:**

1. BMS communication connection is only for lithium battery.
2. With parallel connection mode, it is necessary to connect APP to one of the inverters and then go to Console > Hybrid Setting> Other >Parallel mode page to enable Parallel mode on APP. Please refer to section 7.2.3.
3. About breakers:  
DC breaker on PV side  $\geq 40\text{A}$  (2P) ;  
DC breaker on battery side  $\geq 40\text{A}$ (2P);  
AC breaker on load side  $\geq 32\text{A}$  (4P);  
AC breaker on grid side  $\geq 63\text{A}$  (4P) ;  
The specifications of main breaker and normal load breaker depend on household loads.

 **Danger**

Ensure that the inverter and all cables to be installed have been completely powered off during the whole process of installation and connection. Otherwise, fatal injury could be caused by the high voltage.

# Parallel connection mode-Scheme B ( $2 < N \leq 9$ )

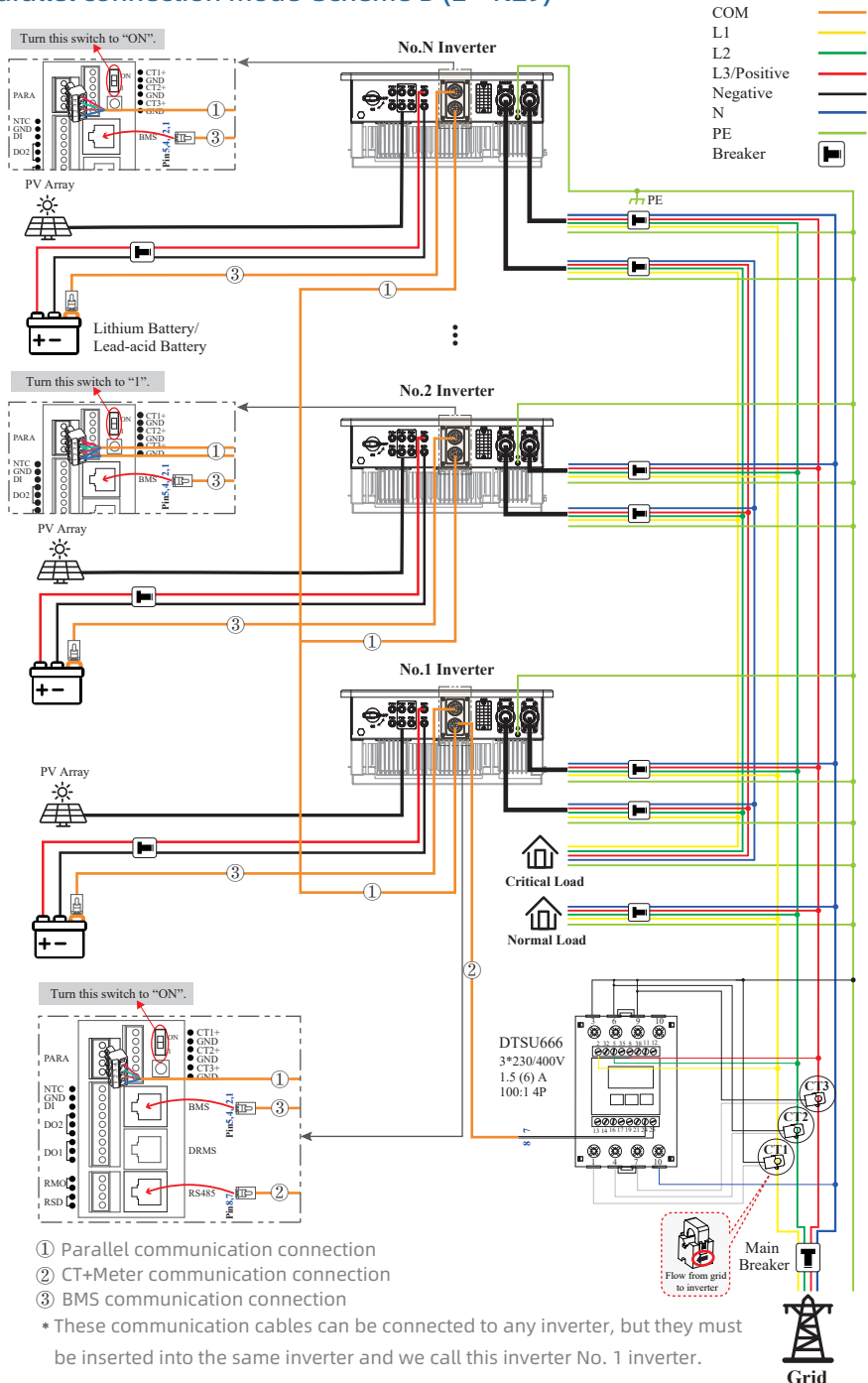

### Note for Scheme B:

1. BMS communication connection is only for lithium battery.
2. It is necessary to turn the matched resistance switch No. 1 inverter and No. N inverter to "ON" and turn others to "1" in parallel connection mode.
3. With parallel connection mode, it is necessary to connect APP to one of inverters and then go to Console >Hybrid Setting> Other >Parallel mode page to enable Parallel mode on APP. Please refer to section 7.2.3.
4. About breakers:

DC breaker on battery side  $\geq 80$  A

AC breaker on critical load side  $\geq 40$  A

AC breaker on inverter side  $\geq 40$  A

The specifications of main breaker and normal load breaker depend on household loads.

### Danger

Ensure that the inverter and all cables to be installed have been completely powered off during the whole process of installation and connection. Otherwise, fatal injury could be caused by the high voltage.

## 4.1 Grounding

A protective earth (PE) terminal is equipped at the side of the inverter. Please be sure to connect this PE terminal to the PE bar for reliable grounding. AWG 10 yellow green lines are recommended.

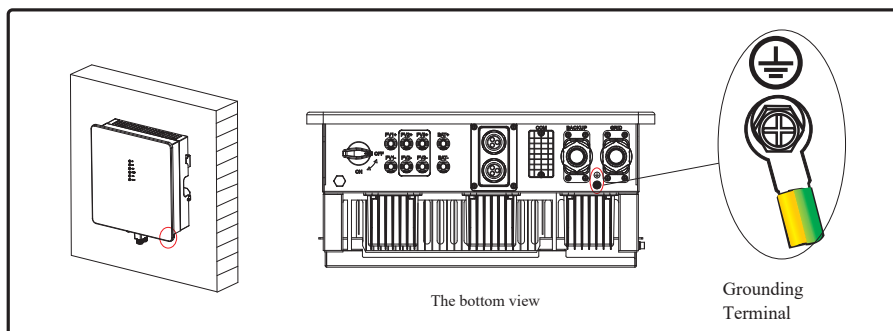

### Danger

The inverter must be grounded; otherwise, there may be electric shock risk.

### Warning

If the positive pole or negative pole of the PV array is required to be grounded, then the inverter output (to AC grid) must be isolated by transformer in accordance with IEC62109-1, -2 standards.

## 4.2 GRID/BACKUP Connection

If necessary, please refer to below to disassemble the GRID/BACKUP terminal.

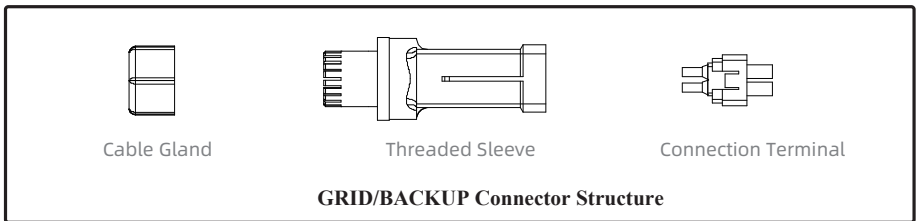
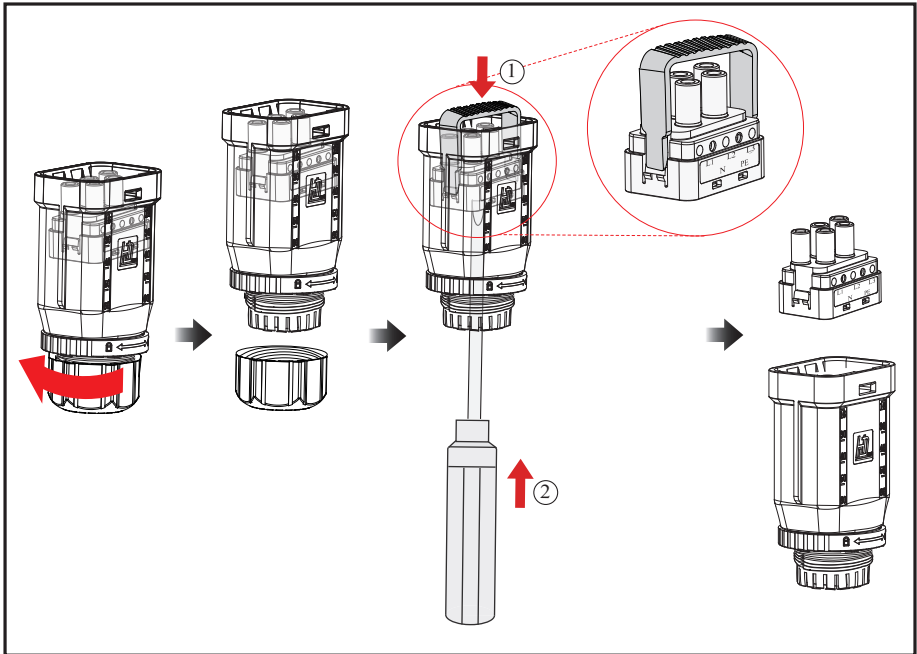

Before connecting the GRID/BACKUP terminal, ensure that both the AC terminal and the DC terminal are powered off and the PV switch is OFF. Otherwise there is a risk of high voltage shock.

GRID/BACKUP connection please refer to below.

**Step 1: Assemble the AC connector.**

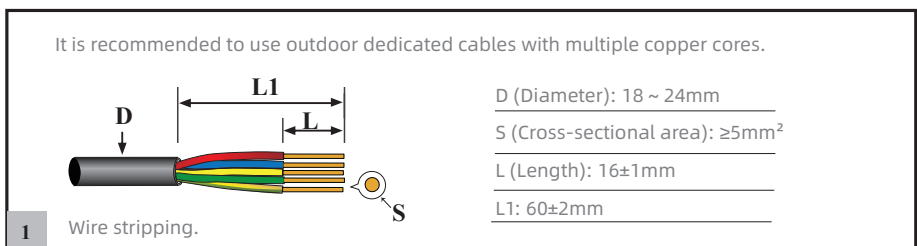

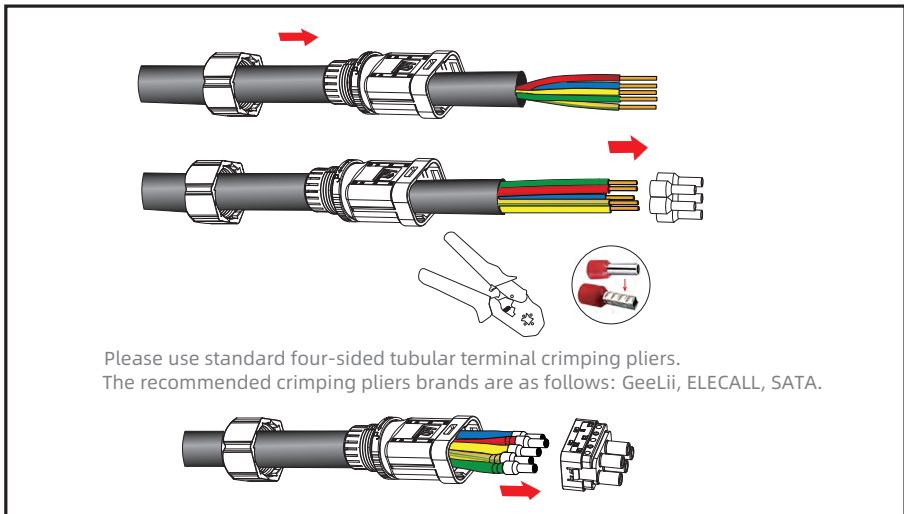

## 2 Wire threading and crimping.

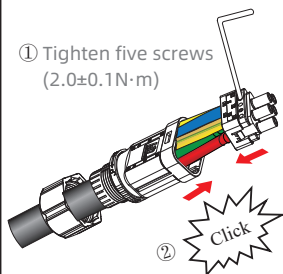

3

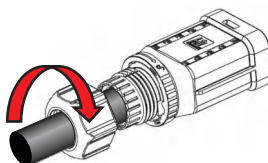

4 Tighten nut to avoid loosening.

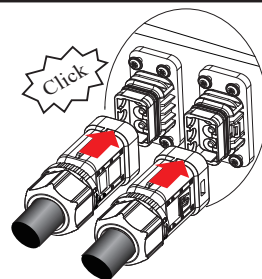

5

Insert the connector into the GRID/BACKUP port.

## Step 2: Connect the AC connector.

An AC breaker(4P) ( $\geq 40\text{A}$ ) should be installed between inverter and the GRID/BACKUP.

- Before connecting the AC cable from inverter to AC breaker, you should confirm the AC breaker is working normally. Turn off the AC breaker and keep the status.
- Connect the PE conductor to grounding electrode, and connect the N and L conductors to AC breaker.
- Connect the AC breakers to the GRID/BACKUP.

## ⚠ Caution

- Multiple inverters are not allowed to share a circuit breaker.
- Load is not allowed to connect between the inverter and the AC breaker(4P).

### 4.3 Battery Connection

Three phase ESS inverter now only supports the lithium / lead-acid battery. The recommended lithium battery brands are as follows: Weco, Pylon tech, UZ energy series.

This part in this manual only describes the battery connection on inverter side. If you need more detailed connection information about the battery side, please refer to the manual of the battery you are using.

Before connecting to battery, please install a separate DC breaker between the inverter and battery. This ensures the inverter can be securely disconnected during maintenance.

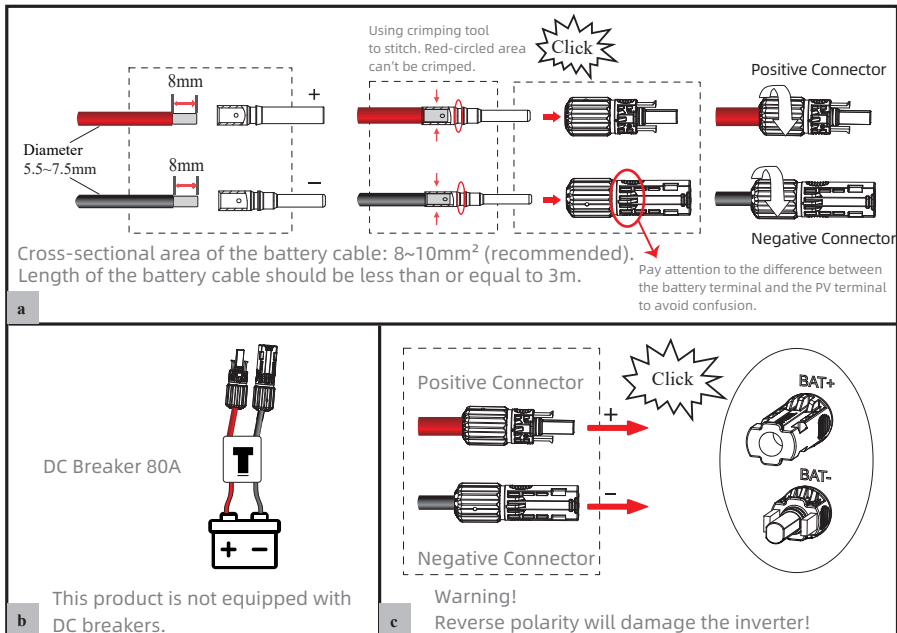

### Warning

- Polarity reverse will damage the inverter!
- Be careful of electric shock and chemical hazards!
- To reduce risk of injury, please use the suitable recommended cable size.

### Battery Communication Connection

If the battery type is lithium battery which need communication between the inverter and battery management system (BMS), the connection must be installed. Please refer to section 4.6.1 for details.

# NTC connection for lead-acid battery

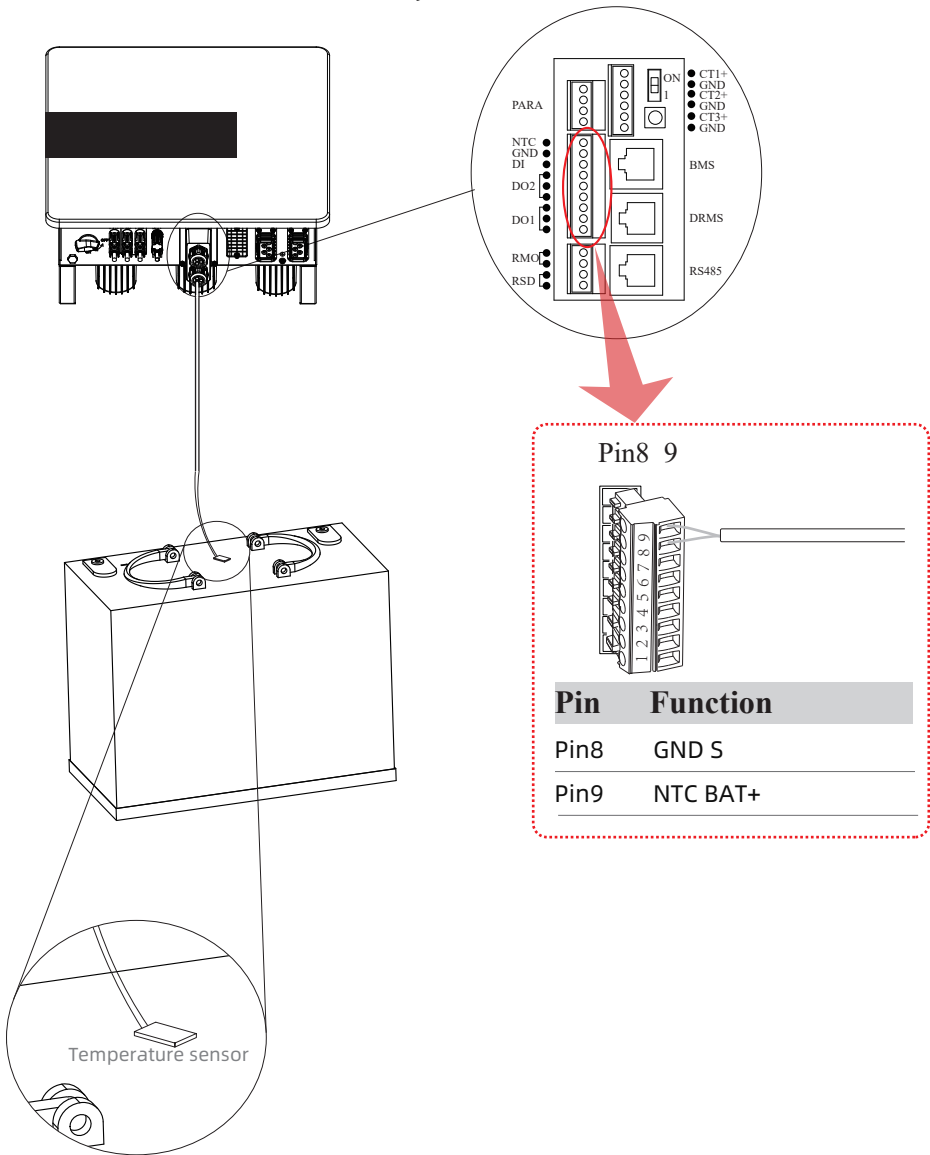

## 4.4 PV Connection

PV connection please refer to below.

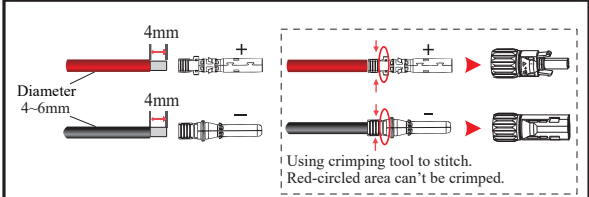
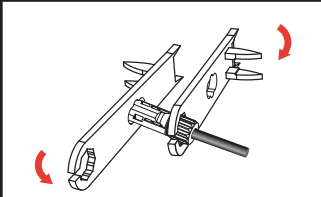
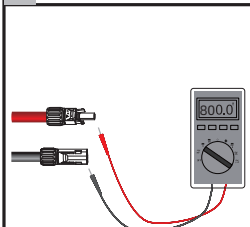
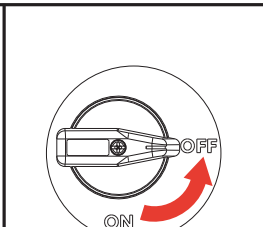
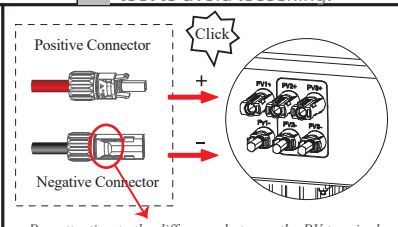
 <p>4mm Diameter 4-6mm</p> <p>Using crimping tool to stitch. Red-circled area can't be crimped.</p> <p>Note: DC cable should be dedicated PV cable (suggest using 4-6mm<sup>2</sup> PV1-F cable).</p> <p><b>1</b> Wires making and crimping.</p>	 <p>Tighten the waterproof nuts on each connector with a tool to avoid loosening.</p> <p><b>2</b></p>	
 <p>Test string voltage and confirm string polarity.</p> <p><b>3</b></p>	 <p>Ensure that the PV switch is OFF.</p> <p><b>4</b></p>	 <p>Positive Connector</p> <p>Negative Connector</p> <p>Click</p> <p>Pay attention to the difference between the PV terminal and the battery terminal to avoid confusion.</p> <p>Insert the positive and negative connectors into the PV+/PV- ports until a "click" sound is heard.</p> <p><b>5</b></p>

### Danger

Please check polarity of PV connectors!

If polarity is reversed, do not try to disconnect any PV connector until the irradiance declines and the DC currents fall below 0.5 A!

Only then disconnect the PV plugs and correct the polarity before reconnecting.

### Warning

- Before connection the PV panels, make sure the plug connector have the correct polarity. Incorrect polarity could permanently damage the inverter.
- PV array shouldn't be connected to the grounding conductor.
- The minimum insulation resistance to ground of the PV panels must exceed 18.33k $\Omega$ , there is a risk of shock hazard if the requirement of minimum resistance is not met.

## 4.5 Meter/CT Connection (Direct connect)

You can monitor usage with a meter or a CT.

### 4.5.1 Meter Connection

This section is applicable to non-parallel connection mode only.

Three phase ESS inverter supports the meter CHINT-DTSU666 meter by default.

The meter is optional.

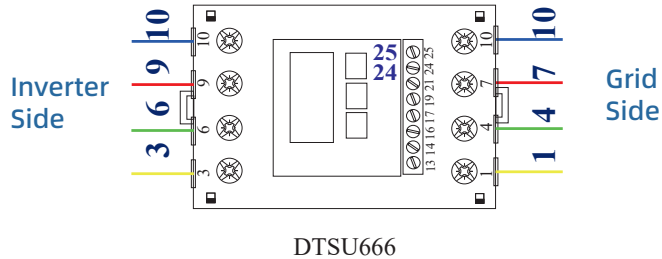

Before connecting to Grid, please install a separate AC breaker ( $\geq 40A$ ; not equipped) between meter and Grid. This ensures the inverter can be securely disconnected during maintenance.

The connection diagram of power cable of meter is as shown in the figure below:

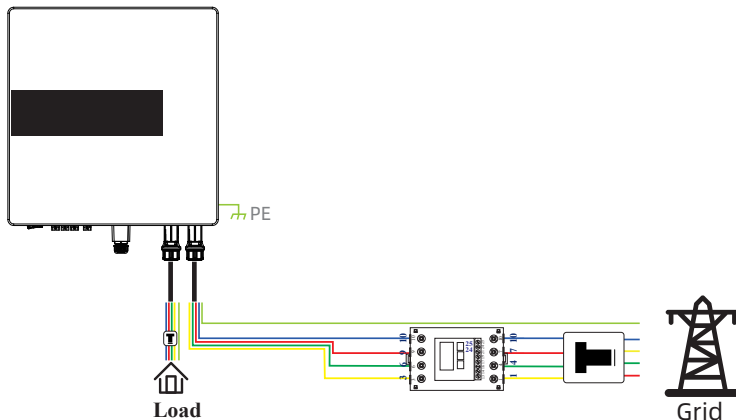

Please refer to the meter instruction manual for details.

## 4.5.2 CT Connection

Before connecting to Grid, please install a separate AC breaker ( $\geq 40\text{A}$ ; not equipped) between CT and Grid. This ensures the inverter can be securely disconnected during maintenance.

The connection diagram of power cable of CT is as shown in the figure below:

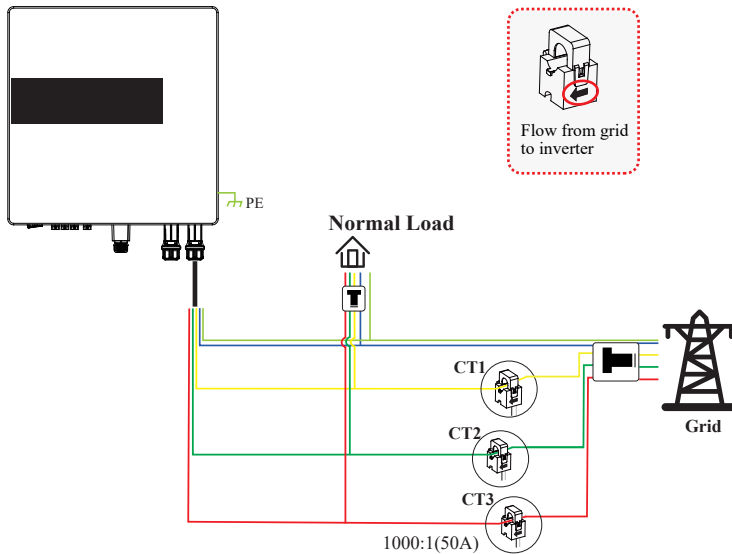

Please pay attention to the Current transformer (CT) connection. The arrow on the CT indicates the current flow from grid to inverter. And lead the live line through the detection hole of CT.

### **Caution**

The current direction from grid to inverter is defined as positive and current direction from inverter to grid is defined as negative.

## 4.6 Communication Connection

There are communication interfaces in the communication port on the bottom of the inverter as show below:

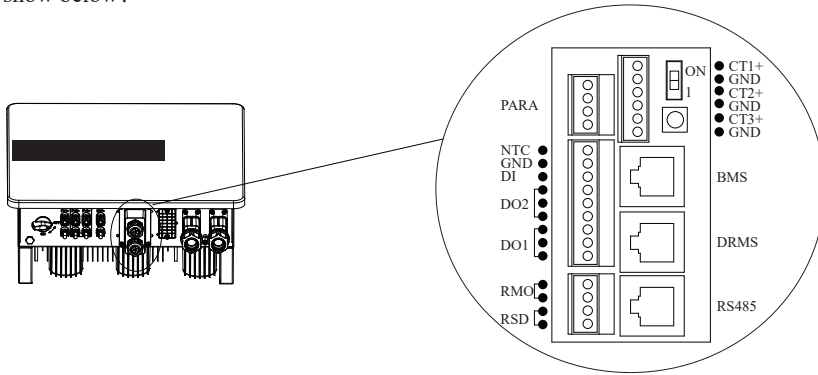

Interface		Descriptions
PARA		4-Pin interface for parallel communication
		A matched resistance switch for parallel communication
RS485		RS485 communication (Monitoring/Meter)
DRMS		Demand response mode for Australia application
CT		6-Pin interface for grid/load current sensor.
BMS		Lithium battery communication interface
9-Pin	NTC	Temperature sensor terminal of lead-acid battery
	DRY	DI/DO control
RSD/RMO		RSD control power and remote off
COM		For WIFI/LAN communication.

## 4.6.1 BMS Connection (Only for Lithium Battery)

### RJ45 Terminal Configuration of Battery Communication at Inverter Side

#### **Caution**

This manual ONLY illustrates the pinout sequence of BMS at INVERTER SIDE. For details about the pinout sequence at battery side, see the user manual of the battery you use, and the following pinout diagram of battery side is only for illustration.

#### Standard RJ45 Pinout

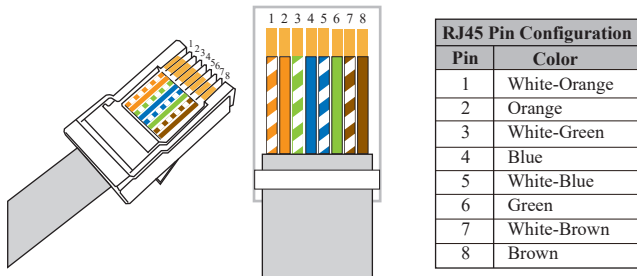

Always face the flat side of the terminal, and count the pin slots from left to right correspond to 1 to 8.

Read the pin definitions of both the battery and inverter carefully.

#### Pin definition of terminal

##### INVERTER:

Inverter	
Pin	Definition
1	RS485_A
2	RS485_B
3	GND
4	CAN_H
5	CAN_L
6	/
7	/
8	/

##### BATTERY:

An example of the battery's pin configuration is as following.

Battery (example)	
Pin	Definition
1	NC
2	NC
3	GND_S
4	CAN_H
5	CAN_L
6	GND_S
7	NC
8	NC

CAN BUS connection principle:

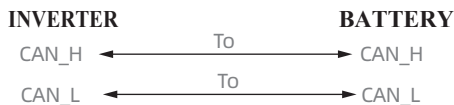

## BMS communication cable preparation.

- ① Prepare RJ45 terminals and strip appropriate length of COM cables.
- ② According to pin definitions and cable order, assemble the RJ45 terminals and crimp communication wires. There are two methods to assemble the RJ45 terminals.
- ③ Then label the RJ45 terminals (BAT or INV) to avoid confusion.
- ④ After finishing wire-making, use a multimeter or other specific tool to determine if your cable is good, bad, or wired incorrectly.

**Method 1:** Use the INVERTER RJ45 pinout as the standard pinout to crimp wires, then the battery side will be a non-standard one (special pinout). Cut off the other no-used wires (1/2/3/6/7/8) for the battery RJ45 terminal.



**Method 2:** Use the BATTERY RJ45 pinout as the standard pinout to crimp wires, then the inverter side will be a non-standard one (special pinout). Cut off the other no-used wires (1/2/3/6/7/8) for the inverter RJ45 terminal.



## BMS communication cable connection.

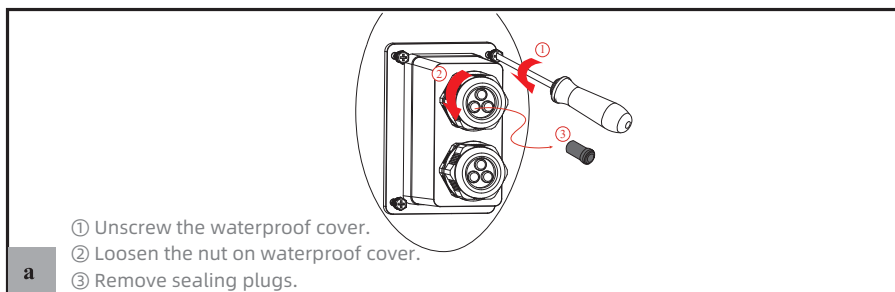

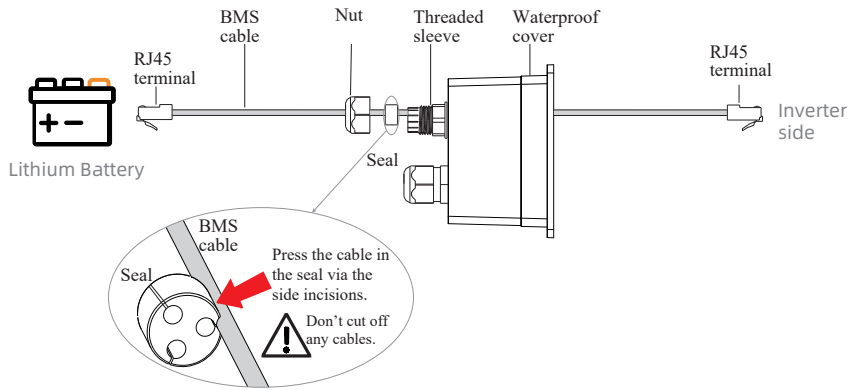

**b** Lead the BMS cable through the nut, seal and waterproof cover in turn.

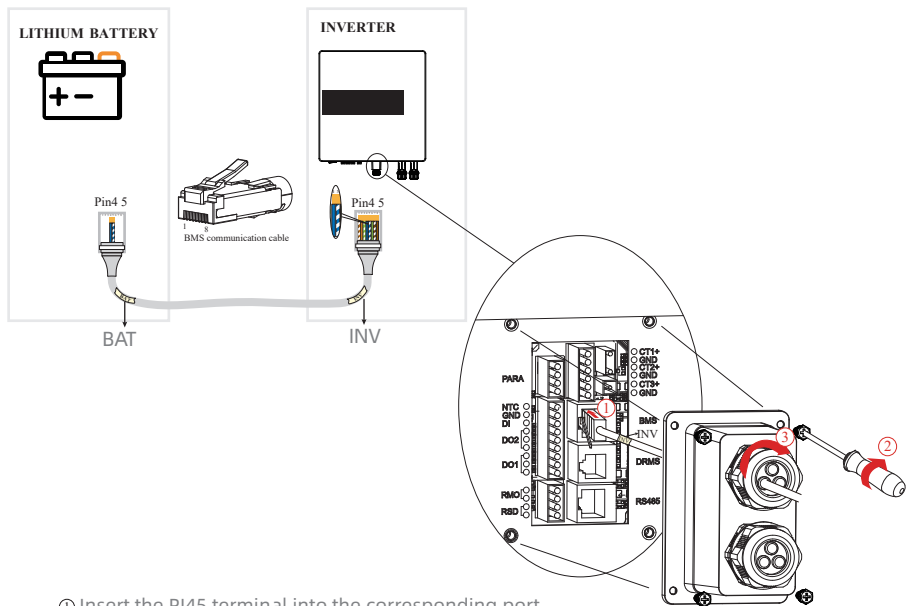

- ① Insert the RJ45 terminal into the corresponding port.
- ② Screw the waterproof cover back to inverter firmly with 4 x M4 screws(1.2N·m).
- ③ Install the seal into the threaded sleeve, fasten the nut.

**c**

## 4.6.2 DRMs Connection

DRMs is a shortened form for “inverter demand response modes”. It is a compulsory requirement for inverters in Australia.

Note: With DRMs connection, it is necessary to connect APP to inverter and then go to [Console > Other Setting](#) page to enable [DRM function](#) on APP. Please refer to section 7.2.3.

### RJ45 Terminal Configuration of DRMs

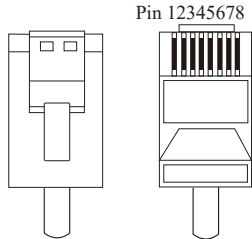

DRMs

PIN	1	2	3	4	5	6	7	8
Function Description	DRMs1/5	DRMs2/6	DRMs3/7	DRMs4/8	REF	GND	/	/

Refer to the following steps:

**a**

- ① Unscrew the waterproof cover.
- ② Loosen the nut on waterproof cover.
- ③ Remove sealing plugs.

**b**

- ① Insert the RJ45 terminal into the corresponding port.
- ② Screw the waterproof cover back to inverter firmly with 4 x M4 screws (1.2N-m).
- ③ Install the seal into the threaded sleeve, fasten the nut.

Make the RJ45 terminal according to above function description of each Pin definition.  
Lead the DRMs/RCR cable through the nut, seal and waterproof cover in turn.

**⚠ Don't cut off any communication cables.**

Press the DRMs cable in the seal via the side incisions.

### 4.6.3 RS485 Communication (Monitoring/Meter Connection)

#### RJ45 Terminal Configuration of Monitoring/Meter Communication

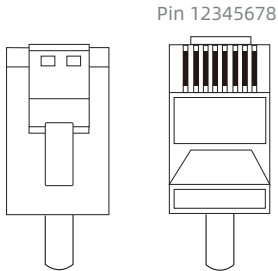

PIN	1	2	3	4	5	6	7	8
Function Description	RS485_A	RS485_B	/	/	/	/	RS485_A	RS485_B

Inverter	Meter
Pin7(RS485_A)	Pin24
Pin8(RS485_B)	Pin25

Inverter	Monitoring
Pin1(RS485_A)	RS485_A
Pin2(RS485_B)	RS485_B

#### Meter cable connection overview

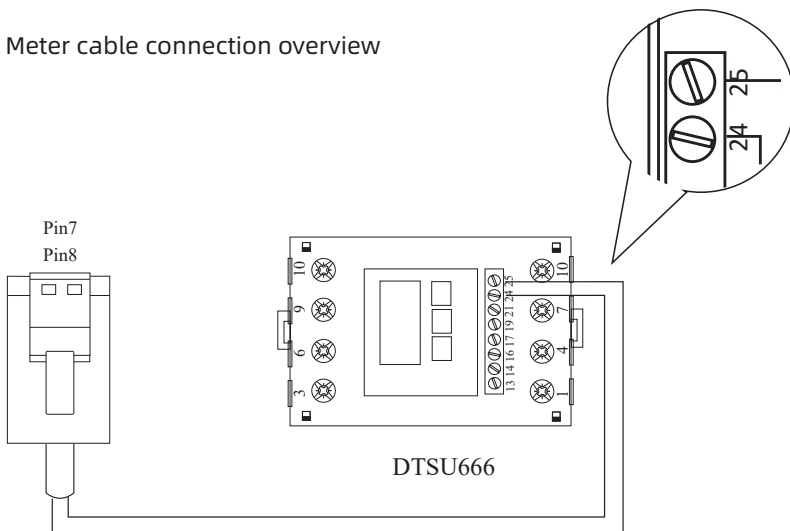

Connect meter. Refer to the following steps:

<p><b>a</b></p> <ol style="list-style-type: none"> <li>① Unscrew the waterproof cover.</li> <li>② Loosen the nut on waterproof cover.</li> <li>③ Remove sealing plugs.</li> </ol>	<p><b>c</b></p> <ol style="list-style-type: none"> <li>① Insert the RJ45 terminal into the corresponding port.</li> <li>② Screw the waterproof cover back to inverter firmly with 4 x M4 screws (1.2N·m).</li> <li>③ Install the seal into the threaded sleeve, fasten the nut.</li> </ol>
<p><b>b</b> Make the RJ45 terminal according to above function description of each Pin definition. Lead the meter communication cable through the nut, seal and waterproof cover in turn.</p>	

#### 4.6.4 CT Connection

##### CT cable connection overview

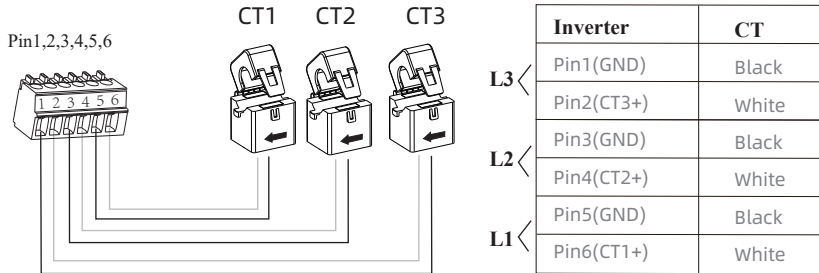

Connect CT. Refer to the following steps:

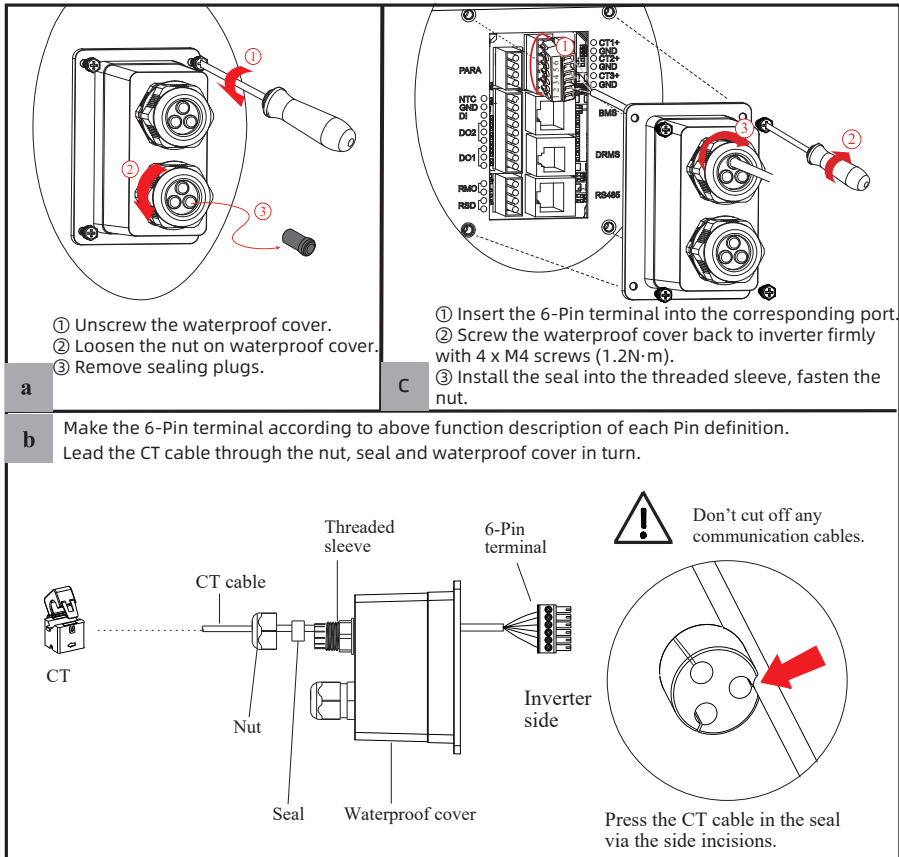

## 4.6.5 Parallel Communication Connection

### 4-Pin Terminal Configuration of parallel Communication

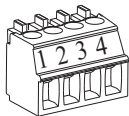

PIN	1	2	3	4
Function Description	GND_S	PARA_SYNC	CAN_L	CAN_H

### Parallel communication cable connection overview

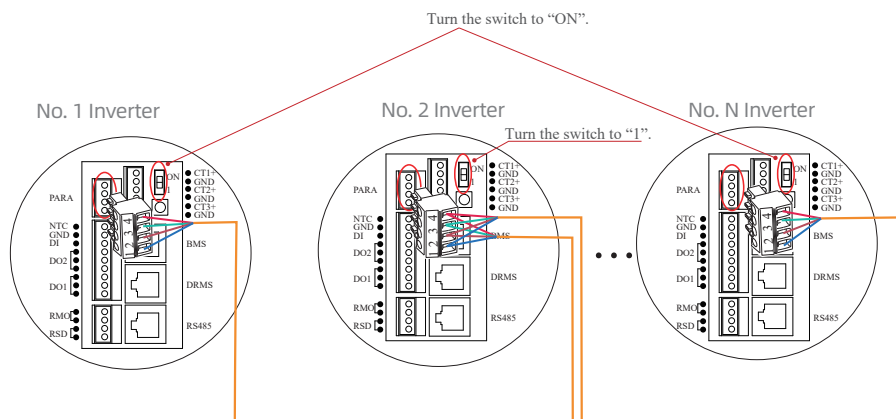

It is necessary to turn the matched resistance switch of No. 1 inverter and No. N inverter to "ON" and turn the matched resistance switch of others to "1" in parallel connection mode.

No. 1 Inverter	No. 2 Inverter	.....	No. N Inverter
Pin4(CAN_H)	Pin4(CAN_H)		Pin4(CAN_H)
Pin3(CAN_L)	Pin3(CAN_L)		Pin3(CAN_L)
Pin2(PARA_SYNC)	Pin2(PARA_SYNC)		Pin2(PARA_SYNC)
Pin1(GND_S)	Pin1(GND_S)		Pin1(GND_S)

Refer to the following steps:

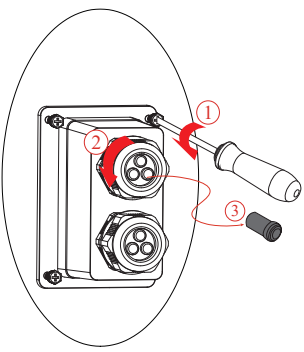
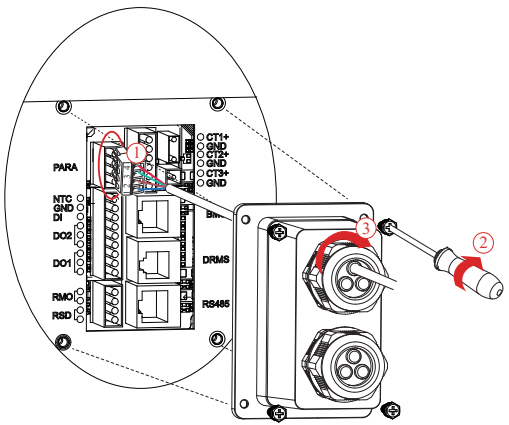
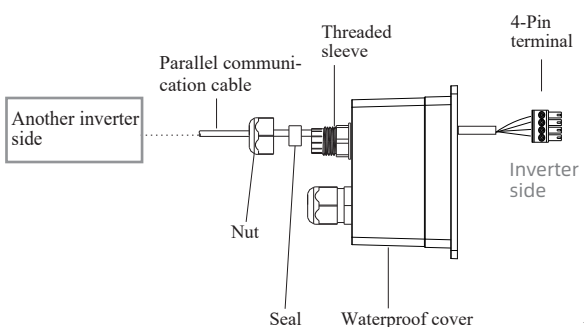
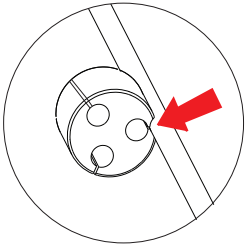
 <p>① Unscrew the waterproof cover. ② Loosen the nut on waterproof cover. ③ Remove sealing plugs.</p> <p><b>a</b></p>	 <p>① Insert the 4-Pin terminal into the corresponding port. ② Screw the waterproof cover back to inverter firmly with 4 x M4 screws (1.2N·m). ③ Install the seal into the threaded sleeve, fasten the nut.</p> <p><b>c</b></p>
<p><b>b</b> Make the 4-Pin terminal according to above function description of each Pin definition. Lead the Parallel cable through the nut, seal and waterproof cover in turn.</p>  <p>Don't cut off any communication cables.</p>  <p>Press the Parallel communication cable in the seal via the side incisions.</p>	

#### 4.6.6 NTC/DI/DO Connection(s)

##### 9-Pin Terminal Configuration of Auxiliary Communication

Pin 123456789

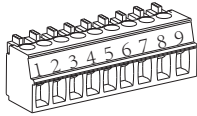

PIN	Function Description
1	NO (Normal Open)
2	COM
3	NC (Normal Close)
4	NO (Normal Open)
5	COM
6	NC (Normal Close)
7	DI
8	GND S
9	NTC BAT+

Refer to the following steps:

a

- ① Unscrew the waterproof cover.
- ② Loosen the nut on waterproof cover.
- ③ Remove sealing plugs.

b

Make the 9-Pin terminal according to above function description of each Pin definition for the auxiliary port you want to use.

Lead the NTC/DI/DO cable(s) through the nut, seal and waterproof cover in turn.

Press the NTC/DI/DO cable(s) in the seal via the side incisions.

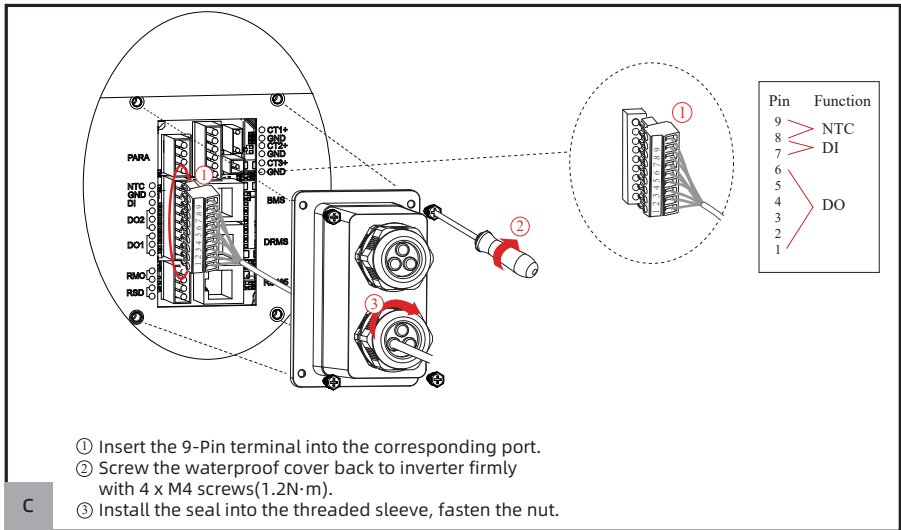

#### 4.6.7 RSD/RMO Connection(s)

##### 4-Pin Terminal Configuration of RSD/RMO Communication

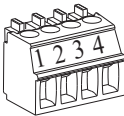

PIN	1	2	3	4
<b>Function Description</b>	+12V	GND	GND	REMOTE OFF

Refer to the following steps:

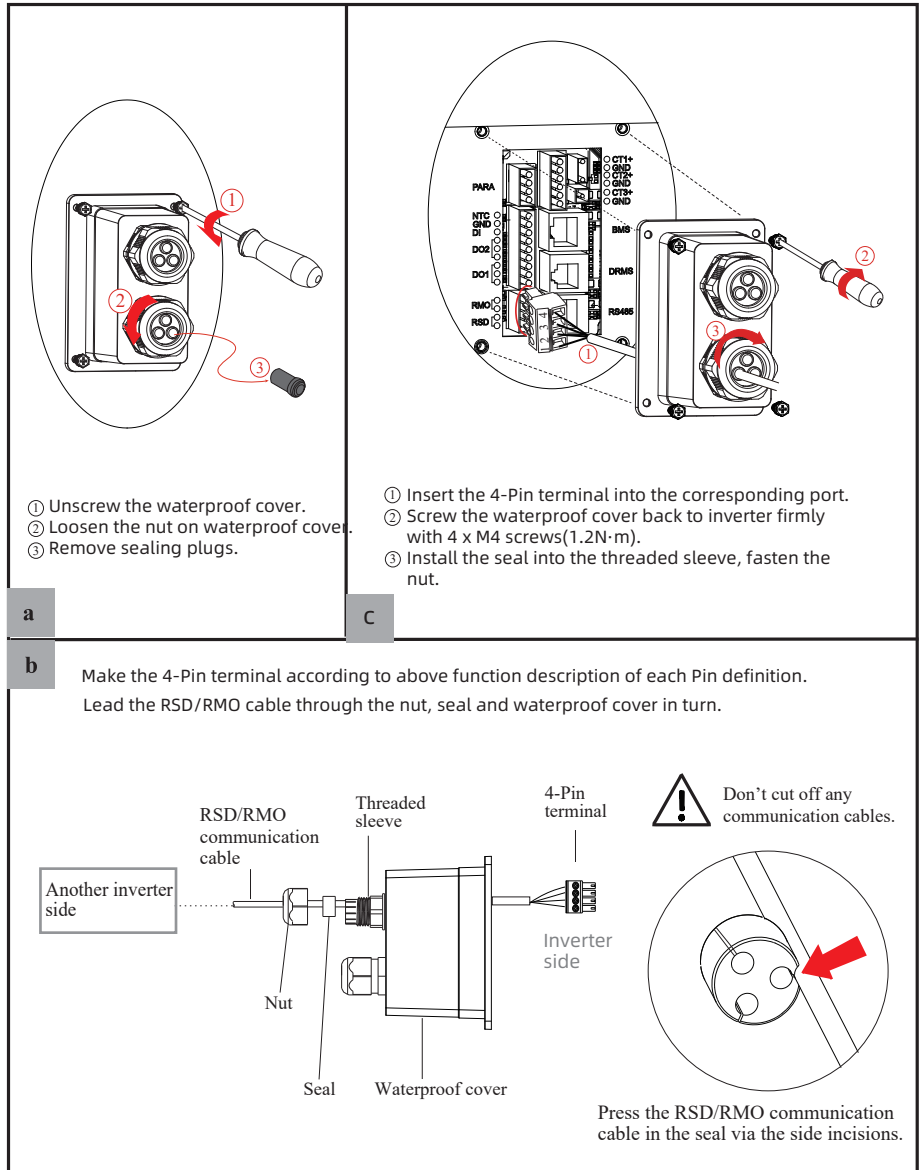

#### 4.6.8 WiFi/LAN Module Connection (Optional)

For details, please refer to the corresponding Module Installation Guide in the packing.

The appearance of modules may be slightly different. The figure shown here is only for illustration.

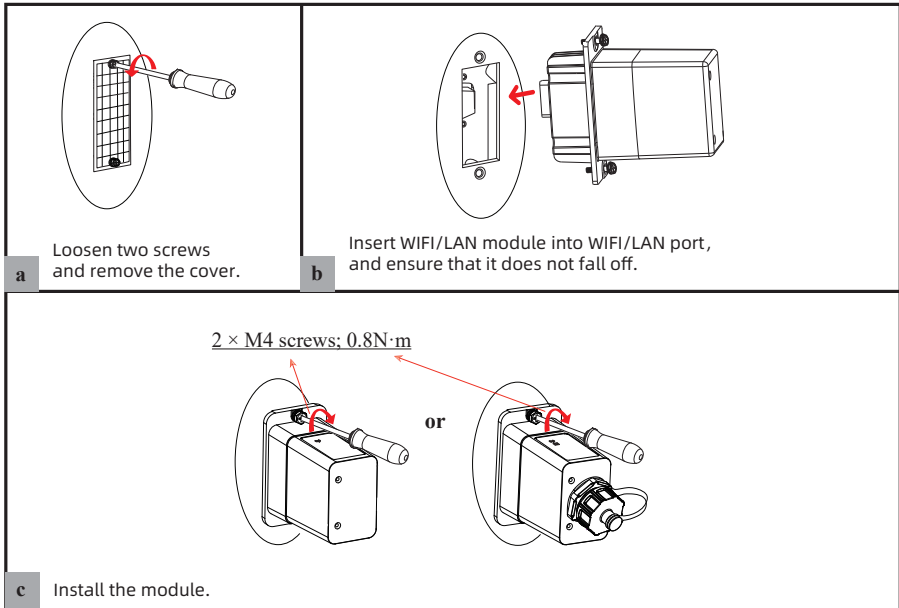

## 5. System Operation

### 5.1 Inverter Working Mode

The inverter supports several different working modes.

#### 5.1.1 Self-consumption Mode

Go to [Console > Hybrid Setting > Work](#) mode page, and select **Self-consumption** mode.

Under Self-consumption mode, the priority of PV energy consumption will be Load > Battery > Grid, that means the energy produced by PV gives priority to powering local loads, the excess energy is used to charge the battery and the remaining energy is fed into the grid.

This is the default mode to increase self-consumption rate. There are several situations of Self-consumption working mode based on PV energy.

#### a) Wealthy PV Energy

When PV energy is wealthy, the PV energy will be first consumed by loads, the excess energy will be used to charge the battery and then the remaining energy will be fed into the grid.

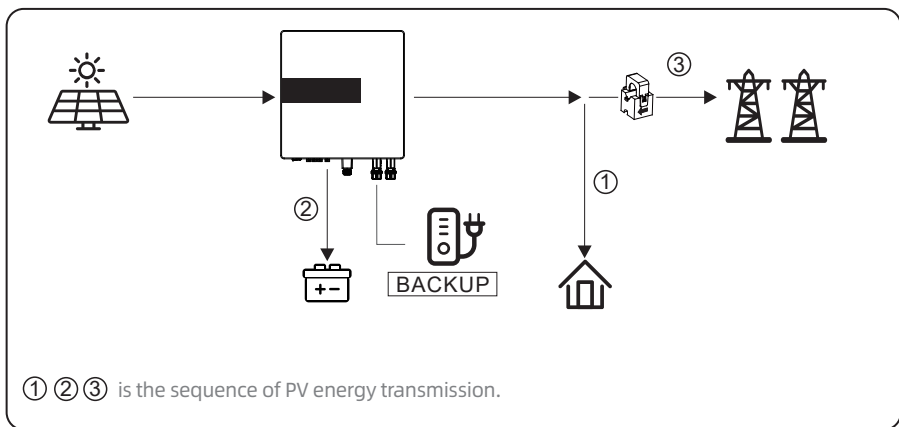

#### b) Limited PV power

When the PV energy is not enough to cover all consumption, the PV energy will be entirely used by loads, and the insufficient part will be supplied by battery. Then still insufficient parts will be supplied by grid.

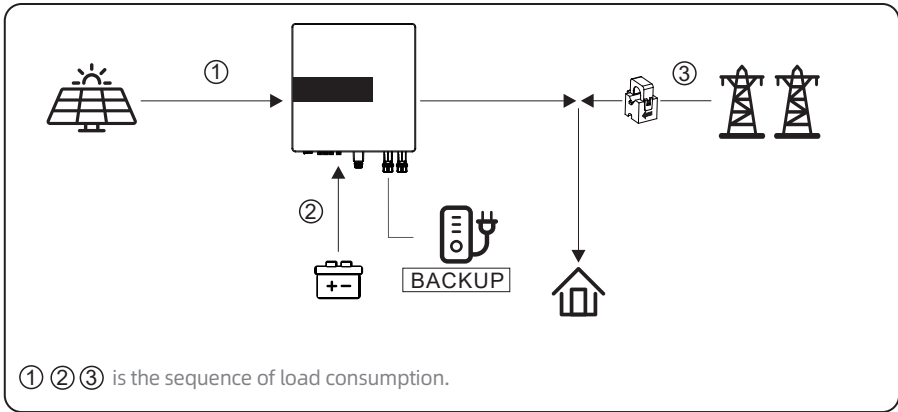

### c) No PV Input

The inverter will first discharge the battery energy for home load consuming when no PV input (such as in the evening or some cloudy or rainy days). If the demand is not met, the loads will consume grid energy.

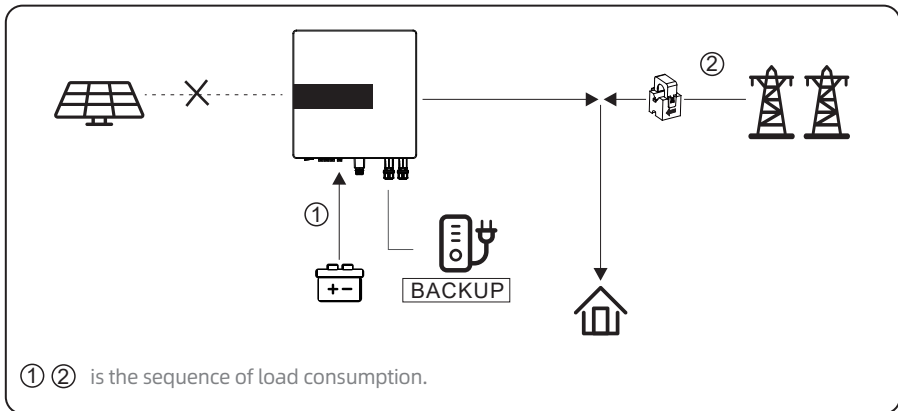

### 5.1.2 Feed-in Priority Mode

Go to [Console > Hybrid Setting > Work mode](#) page, and select **Feed-in priority** mode.

Under this mode, the priority of PV energy consumption will be **Load > Grid > Battery**, that means the energy produced by PV gives priority to powering local loads, the excess energy is fed into the grid, and the remaining energy is used to charge the battery.

### a) Wealthy PV Energy

When PV energy is wealthy, the PV energy will be first consumed by loads. If there is excess PV power, the power will be fed into grid. If there is still PV energy left after load consuming and grid feeding, then the remaining PV power will be used to charge the battery.

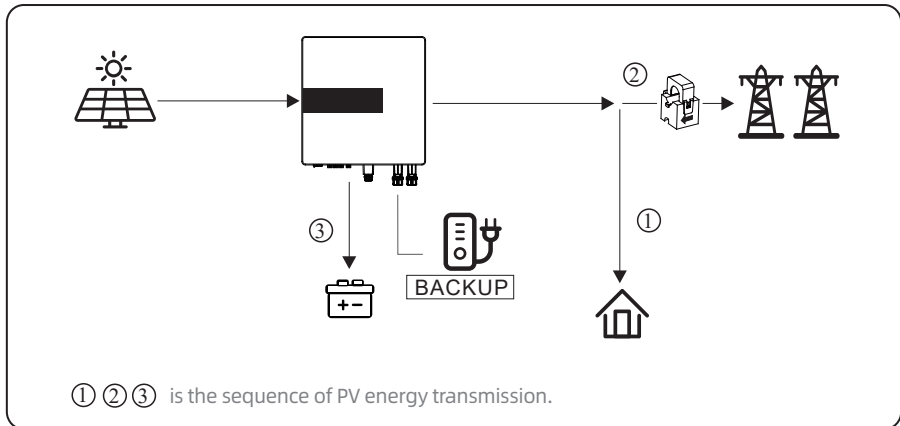

### b) Limited PV Energy

When PV energy is limited and can not meet the feed-in grid power, the battery will discharge to meet it.

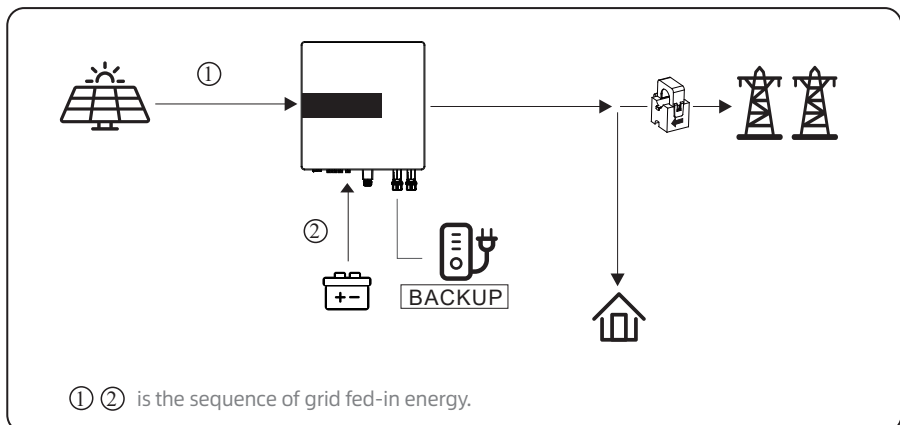

### c) No PV Input

The inverter will first discharge the battery energy for home load consuming when no PV input (such as in the evening or some cloudy or rainy days). If the demand is not met, the loads will consume the grid energy.

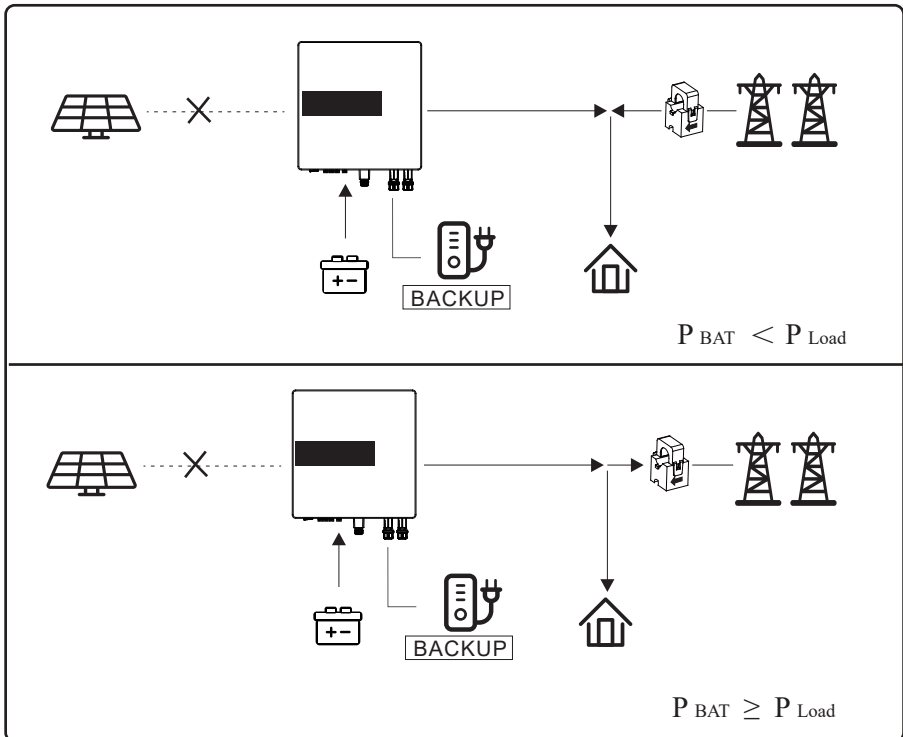

### 5.1.3 Back-up Mode

Go to [Console > Hybrid Setting > Work mode](#) page, and select [Back-up mode](#).

Under this mode, the priority of PV energy consumption will be Battery > Load > Grid.

This mode aims at charging the battery quickly, and at the same time, you can choose whether to allow AC to charge the battery.

#### Forbid AC charging

In this mode, the battery can be charged only with PV power, and the charging power varies with PV power.

#### a) Wealthy PV power

When PV energy is wealthy, PV charges the battery first, then meets the load, and the rest is fed into the grid.

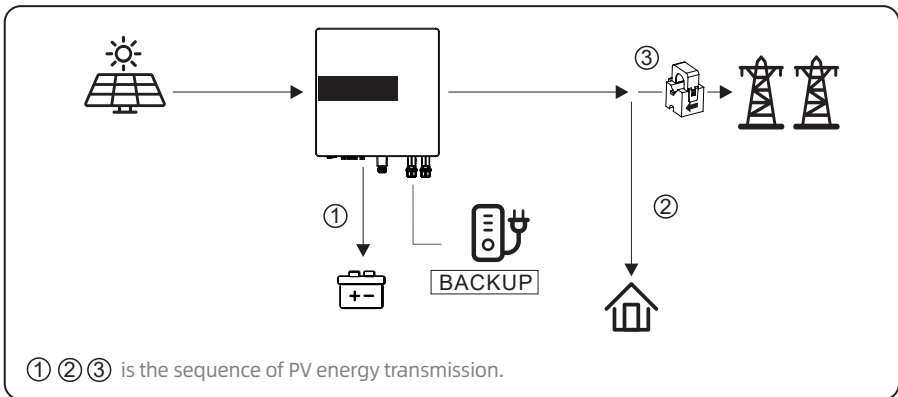

#### b) Limited PV power

When PV energy is limited, PV gives priority to charging the battery, and the grid directly meet the load demand.

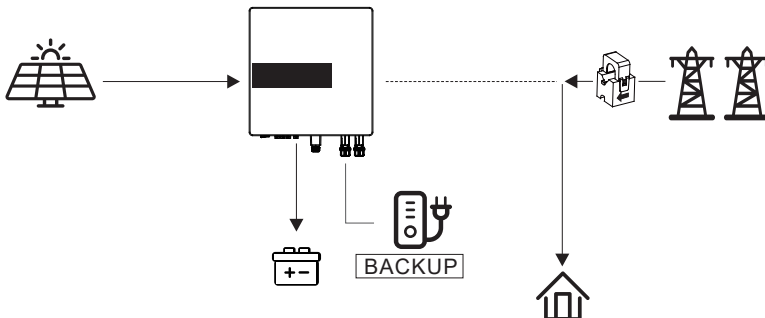

## Allow AC charging

In this situation, the battery can be charged both with PV and AC.

### a) Wealthy PV power

When PV energy is wealthy, PV charges the battery first, then meets the load, and the rest is fed into the grid.

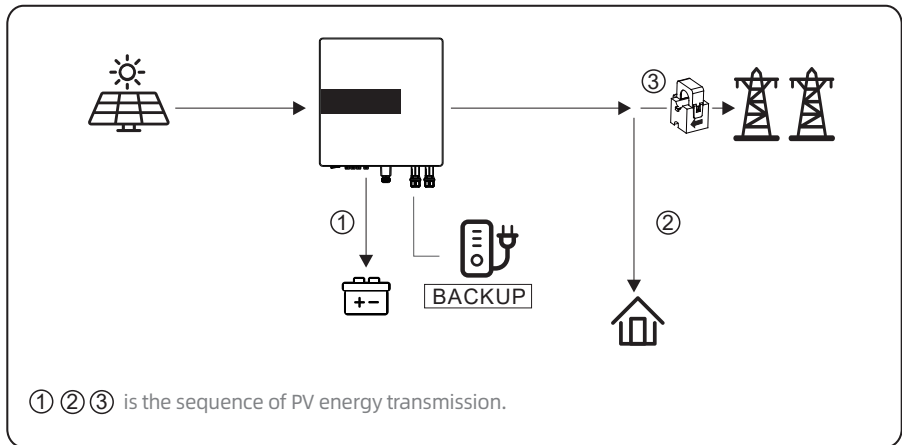

### b) Limited PV power

When the PV energy is not enough to charge the battery, the grid energy will charge the battery as supplement. Meanwhile, the grid energy is consumed by loads.

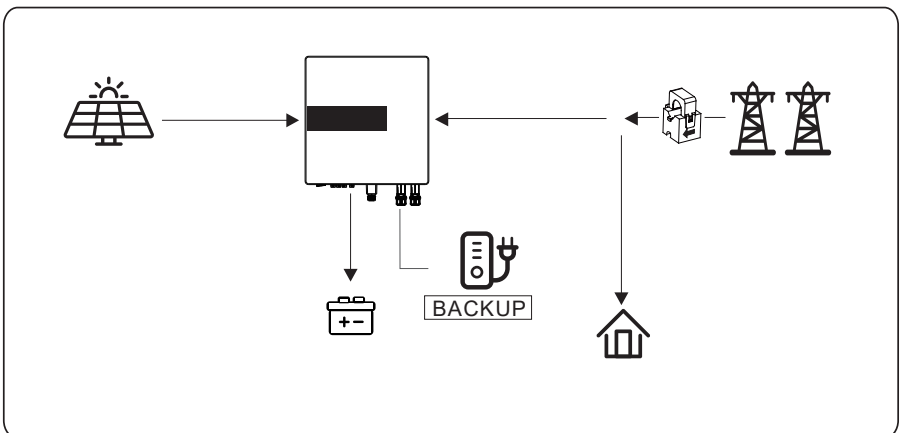

### 5.1.4 Forced Charge/Discharge Function

According to the demands of application, the user can set the inverter to work on forced charge/discharge the battery in any working mode.

Please go to [Console > Hybrid Setting > Work](#) mode to enable [Time-based Control](#) on APP. There are three time periods in which you can set this function. Outside of the set periods, the inverter returns to its original working mode. The forced charge/discharge function has the highest priority. For setting details, refer to Work mode in Console section.

The relationship between the forced charge/discharge function and working mode shown as below.

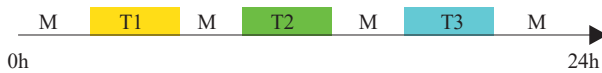

M : Self Use Mode/Feed-in Priority Mode/Back-up Mode

T1: Time period 1 for forced charge/discharge parameter setting

T2: Time period 2 for forced charge/discharge parameter setting

T3: Time period 3 for forced charge/discharge parameter setting

T1, T2, and T3 priority to M.

### 5.1.5 Off Grid Mode

When the power grid is cut off, the system automatically switches to Off Grid mode.

Under off-grid mode, only critical loads are supplied to ensure that important loads continue to work without power failure.

Under this mode, the inverter can't work without the battery.

#### a) Wealthy PV power

When PV energy is wealthy, the PV power will be first consumed by critical load, then charge the battery.

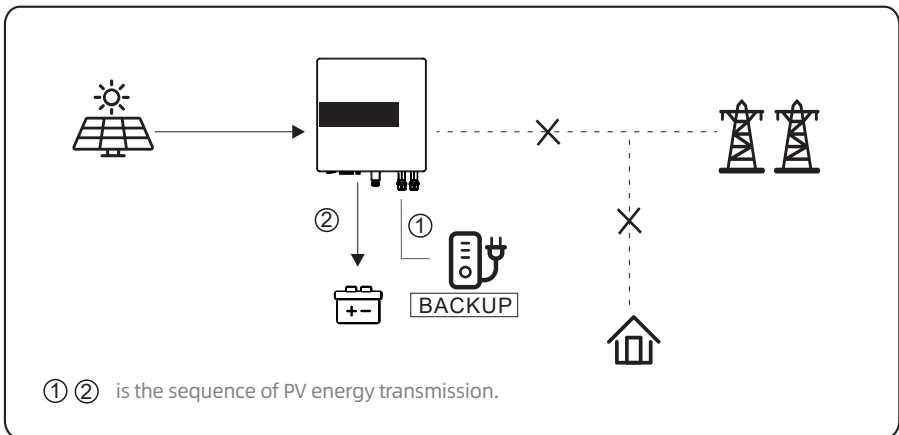

## b) Limited PV power

When PV energy is limited, BACKUP loads are first powered by PV and then supplemented by battery.

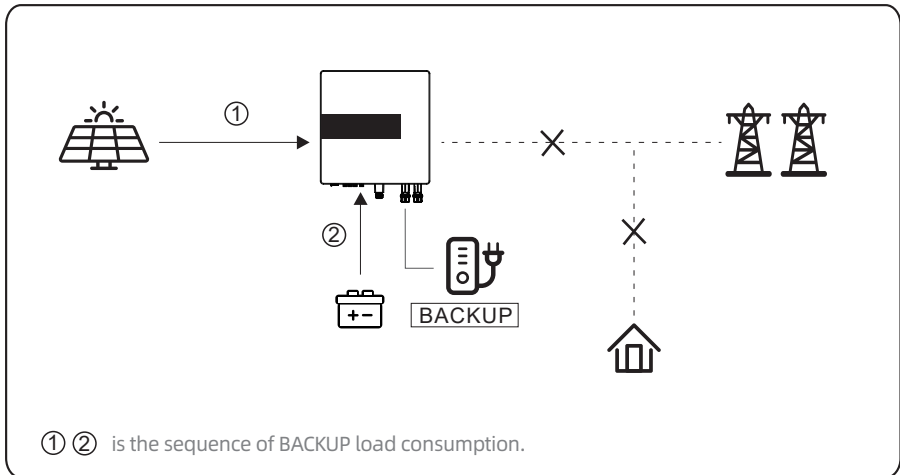

### Danger

- Under this mode, please complete the output voltage and frequency settings.
- It is better to choose the battery with a capacity larger than 100 Ah to ensure BACKUP function work normally.
- If BACKUP output loads are inductive or capacitive loads, to make sure the stability and reliability of system, it is recommended to configure the power of these loads to be within 50% of BACKUP output power range.

## 5.1.6 On-grid Unbalanced Output

- 1) The normal load is single phase.
  - 2) The three phases of normal load are the same or unbalanced.
- This is the best scheme to meet your needs.

On-grid Unbalanced Output

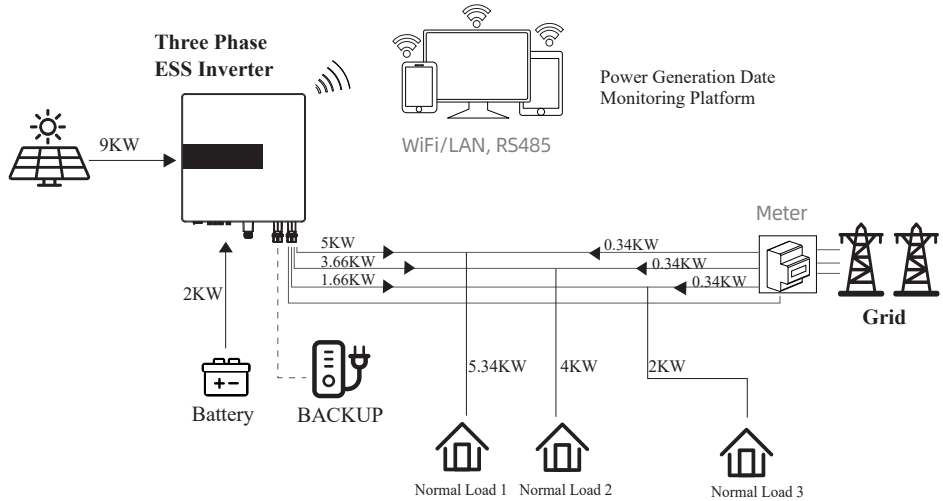

### 5.1.7 Back-up Unbalanced Output

- 1) The critical load is single phase.
- 2) The three phases of critical load are the same or unbalanced.

This is the best scheme to meet your needs.

Back-up Unbalanced Output

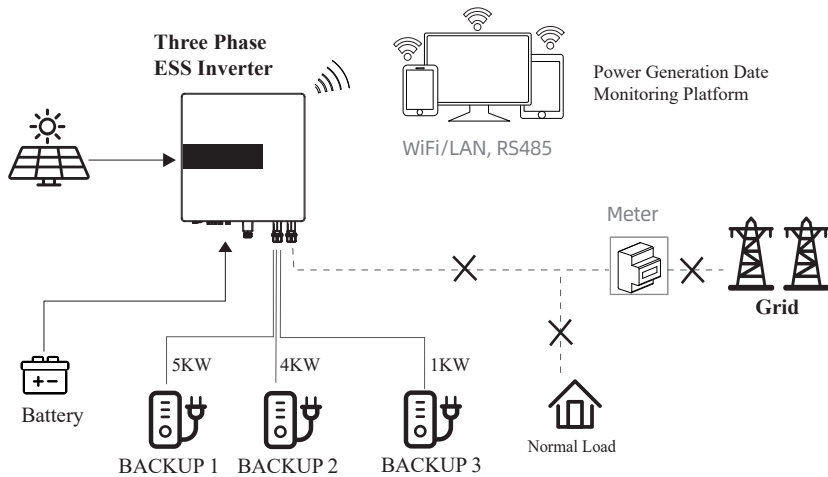

## 5.2 Startup/Shutdown Procedure

### 5.2.1 Startup Procedure

Check and confirm the installation is secure and strong enough and that the system grounding is OK. Then confirm the connections of AC, battery, PV etc. are correct. Confirm that the parameters and configurations conform to relevant requirements.

AC Frequency	50/60Hz	PV Voltage	160~950V
Battery Voltage	150~600V	Grid AC Voltage	180~270V(311~467V)

### Startup Procedure

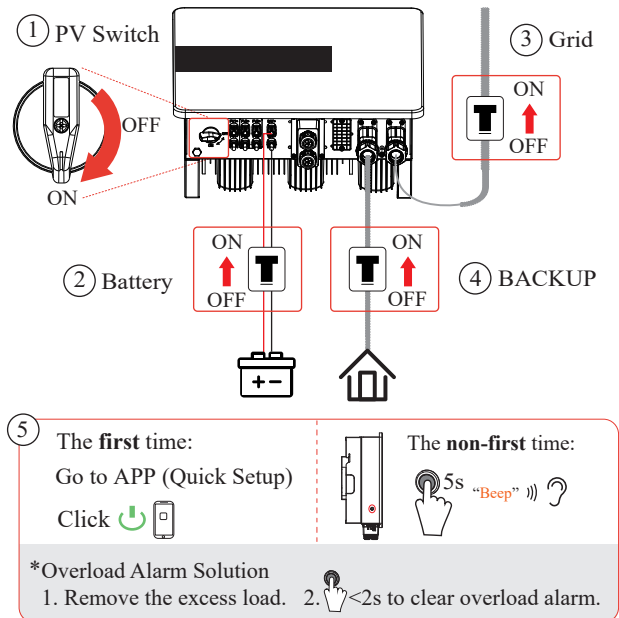

\* To perform the non-first-time startup, press and hold down the button on the left side of the inverter for about 5 seconds, until you hear the "beep" sound.

## Shutdown Procedure

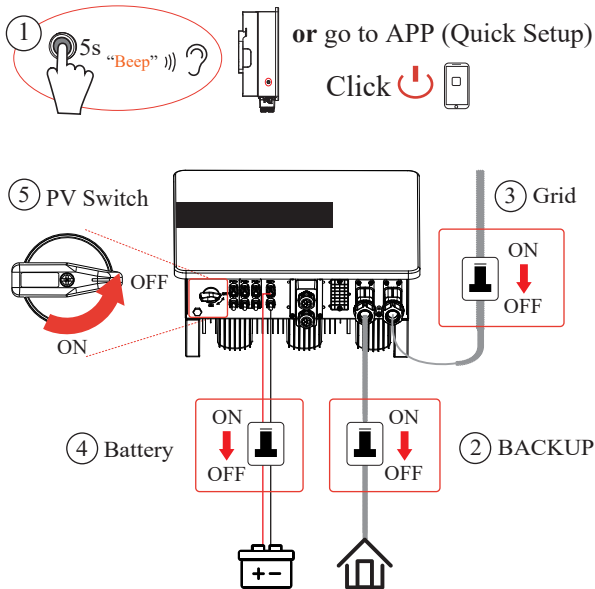

### Danger

After the inverter is powered off, the remaining electricity and heat may still cause electric shock and body burns. If you need to disconnect the inverter cables, please wait at least 10 minutes before touching these parts of the inverter.

## 6. Commissioning

It is necessary to make a complete commissioning of the inverter system. This will essentially protect the system from fire, electric shock or other damages or injuries.

### 6.1 Inspection

Before commissioning, the operator or installer (qualified personnel) must inspect the system carefully and make sure:

- 1) The system is firmly installed correctly following the contents and notifications of this manual, and there are enough spaces for operation, maintenance and ventilation.
- 2) All the terminals and cables are in good status without any damages.
- 3) No items are left on the inverter or within the required clearance section.
- 4) The PV and battery pack are working normally, and the grid is normal.

### 6.2 Commissioning Procedure

After the inspection and make sure status is right, start the system commissioning.

- 1) Power on the system by referring to the Startup Procedure section 5.2.1.
- 2) Setting the parameters on the App according to user's requirement.
- 3) Finish commissioning.

# 7. User Interface

## 7.1 LED

This section describes the LED panel. LED indicator includes PV, BAT, GRID, BACKUP, COM, ALARM indicators.

It includes the explanation of indicator states and summary of indicator states under the running state of the machine.



LED Indicator	Status	Description
PV	On	PV input is normal.
	Blink	PV input is abnormal.
	Off	PV is unavailable.
BAT	On	Battery is charging.
	Blink	Battery is discharging (light on 2s and off 2s). Battery is abnormal (light on 1s and off 1s).
	Off	Battery is unavailable.
GRID	On	GRID is available and normal.
	Blink	GRID is abnormal.
	Off	GRID is unavailable.
BACKUP	On	BACKUP power is available.
	Blink	BACKUP output is abnormal.
	Off	BACKUP power is unavailable.
COM	Blink	Data are communicating.
	Off	No data transmission
ALARM	On	Fault has occurred and inverter shuts down.
	Blink	Alarms has occurred but inverter doesn't shut down.
	Off	No fault.

Details	Code	PV LED	Grid LED	BAT LED	BACKUP LED	COM LED	ALARM LED
PV normal		●	⊙	⊙	⊙	⊙	○
No PV		○	⊙	⊙	⊙	⊙	○
PV over voltage	B0						
PV under voltage	B4						
PV irradiation weak	B5	★	⊙	⊙	⊙	⊙	○
PV string reverse	B7						
PV string abnormal	B3						
On grid							
Bypass output		⊙	●	⊙	⊙	⊙	○
Grid over voltage	A0						
Grid under voltage	A1						
Grid absent	A2						
Grid over frequency	A3	⊙	★	⊙	⊙	⊙	○
Grid under frequency	A4						
Grid abnormal	A6						
Grid over mean voltage	A7						
Neutral live wire reversed	A8						
Battery in charger		⊙	⊙	●	⊙	⊙	○
Battery absent	D1	⊙	⊙	○	⊙	⊙	○
Battery in discharge		⊙	⊙	★★	⊙	⊙	○
Battery under voltage	D3						
Battery over voltage	D2						
Battery discharge over current	D4	⊙	⊙	★	⊙	⊙	○
Battery over temperature	D5						
Battery under temperature	D6						
Communication loss (Inverter - BMS)	D8						
BACKUP output active		⊙	⊙	⊙	●	⊙	⊙
BACKUP output inactive		⊙	⊙	⊙	○	⊙	⊙
BACKUP short circuit	DB						
BACKUP over load	DC						
BACKUP output voltage abnormal	D7	⊙	⊙	⊙	★	⊙	○
BACKUP over dc-bias voltage	CP						

Details	Code	PV LED	Grid LED	BAT LED	BACKUP LED	COM LED	ALARM LED
RS485/DB9/BLE/USB		☉	☉	☉	☉	★	☉
Inverter over temperature	C5						
Fan abnormal	C8						
Inverter in power limit state	CL						
Data logger lost	CH	☉	☉	☉	☉	☉	★
Meter lost	CJ						
Remote off	CN						
PV insulation abnormal	B1						
Leakage current abnormal	B2						
Internal power supply abnormal	C0						
Inverter over dc-bias current	C2						
Inverter relay abnormal	C3						
GFCI abnormal	C6						
System type error	C7						
Unbalance Dc-link voltage	C9						
Dc-link over voltage	CA	☉	☉	☉	☉	☉	●
Internal communication error	CB						
Internal communication loss(E-M)	D9						
Internal communication loss(M-D)	DA						
Software incompatibility	CC						
Internal storage error	CD						
Data inconsistency	CE						
Inverter abnormal	CF						
Boost abnormal	CG						
Dc-dc abnormal	CU						

Remark: ● Light on      ○ Light off      ☉ Keep original status

★ Light on 1s and off 1s      ★★ Light on 2s and off 2s

## 1.1.1 App download

Method 1: Search for "PotisEdge" in the Google Play Store or Apple App Store and download/install the app.

Method 2: Use a mobile browser to visit the following link to download:

<https://ipotisedge-file.s3.eu-central-1.amazonaws.com/h5/download.html#/pages/download/potisedge>

Method 3: Scan the QR code on the device.



## 7.2.2 User register/login

Step 1: Click [Sign Up]

Step 2: Enter your email, click [Send] you will receive a verify code in your email

Step 3: Enter the code

Step 4: Enter your password

Step 5: Select your region

Step 6: Click [Sign Up]

Step 7: Enter your registered email

Step 8: Enter your password

Step 9: Click [Log in]

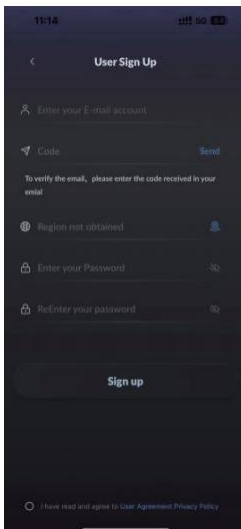
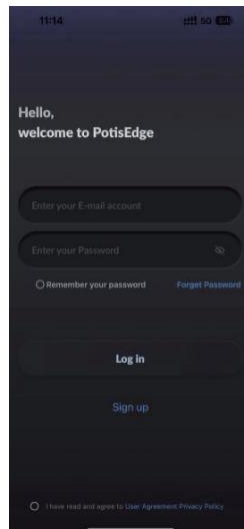
A dark-themed mobile app screen titled "User Sign Up". It features a back arrow at the top left. The form includes: "Enter your E-mail account" with a magnifying glass icon; "Code" with a "Send" button; a note "To verify the email, please enter the code received in your email"; "Region not obtained" with a location pin icon; "Enter your Password" with a strength indicator; and "ReEnter your password" with a strength indicator. A "Sign up" button is at the bottom. A checkbox at the very bottom reads "I have read and agree to User Agreement Privacy Policy".A dark-themed mobile app screen titled "Hello, welcome to PotisEdge". It features a "Log In" button and a "Sign up" button. The form includes: "Enter your E-mail account" with a magnifying glass icon; "Enter your Password" with a strength indicator; and a "Remember your password" checkbox with a "Forgot Password" link. A checkbox at the very bottom reads "I have read and agree to User Agreement Privacy Policy".

## 1.1.2 Add device

Step 1: Click [Add device]

Step 2: Click [Next]

Step 3: Enable Bluetooth permission

Step 4: Select the device you want to connect

Step 5: Select WiFi 's SSID and enter the password

Step 6: Click [Next]

Step 7: Click [Start]

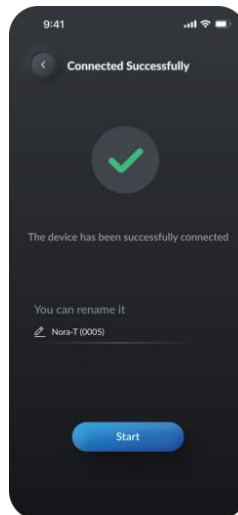
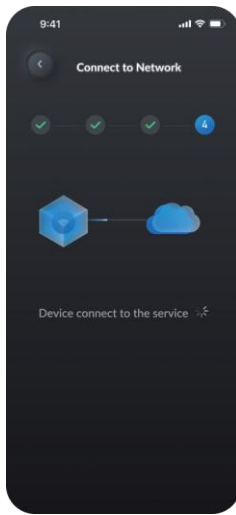
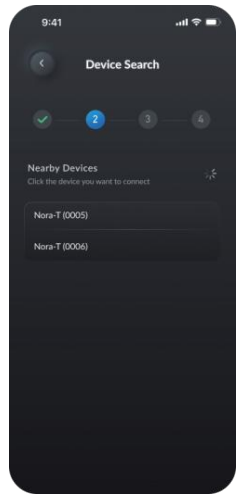
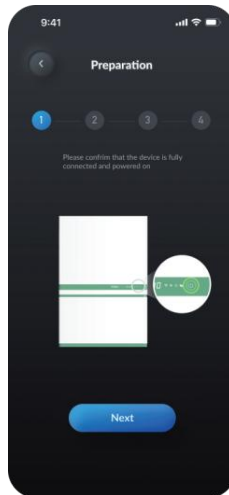
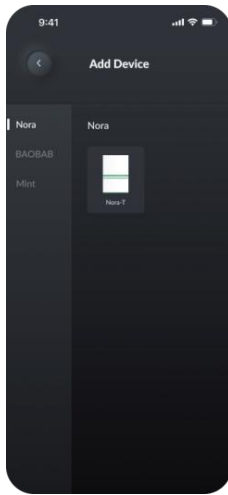
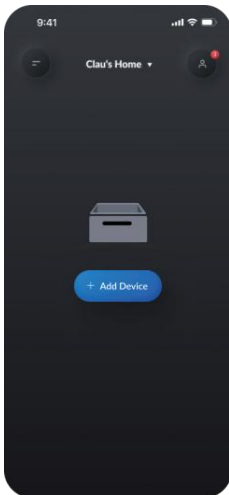

### 1.1.3 Mode settings

After adding the device, you will see the topology of the system

Step 1: Click [device icon] in the topology, enter the device setting page

Step 2: Click [Operation Mode]

Step 3: Switch operation mode

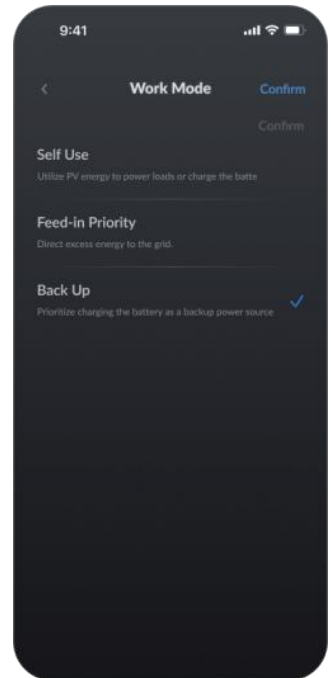
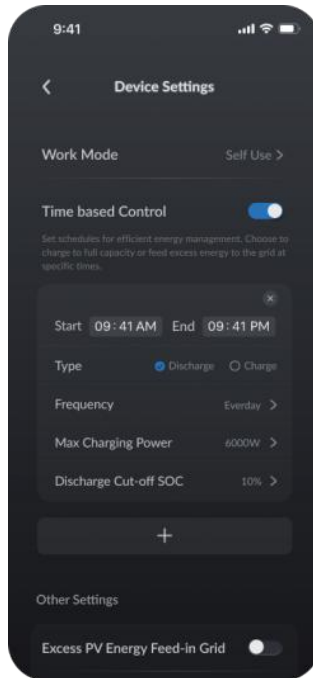

## 1.1.4 Installers connect to device

Step 1: Enter the installer email and password provided by the manufacturer

Step 2: Click [Log in]

Step 3: Click [Add device]

Step 4: Scan the MAC address on the device

Step 5: Click [Confirm]

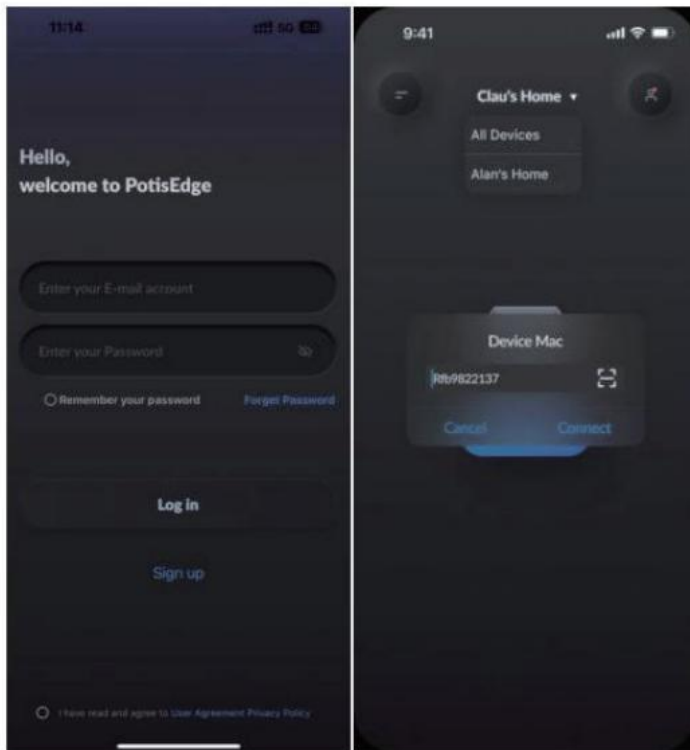

## 1.1.5 System information setting

Step 1: After installer connected to device, you can set the system on a single or parallel mode

Step 2: Enter the parameters of the photovoltaic panel

Step 3: Choose operation mode

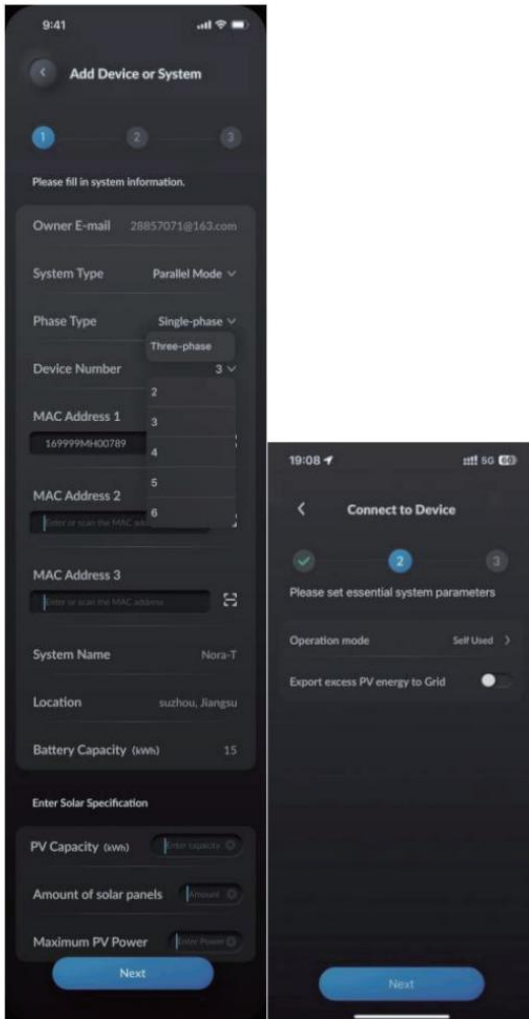

## 1.1.6 Grid Parameters

Tap Console > Grid Parameters to set parameters of grid side. Follow the steps below to configure the country code for Australia under Administrator status.

Note:

Setting or modifying these parameters requires logging into an administrator account.

For Australian Market: Region settings must be selected during commissioning. To comply with AS/NZS 4777.2:2024, please console your local electricity grid operator for which region to select.

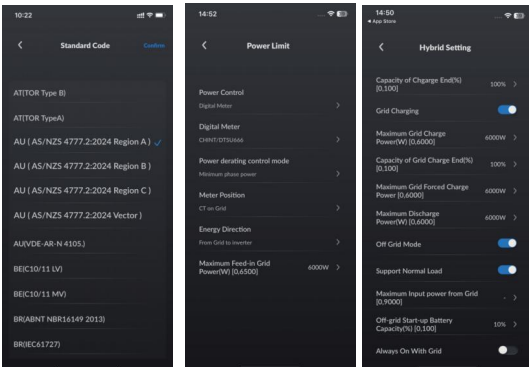
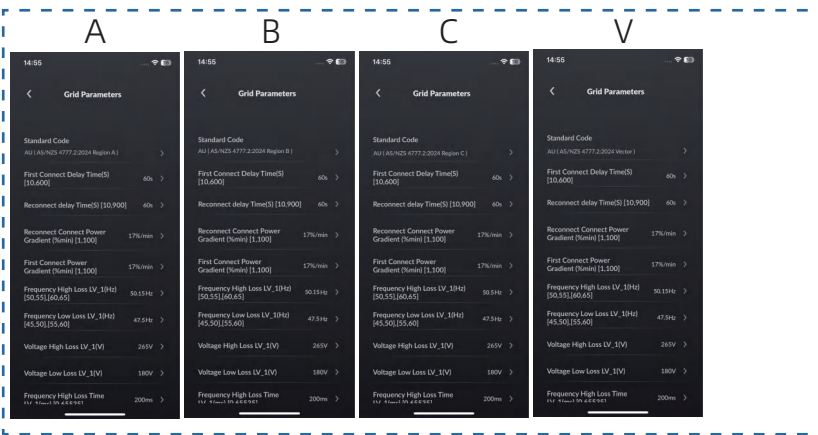
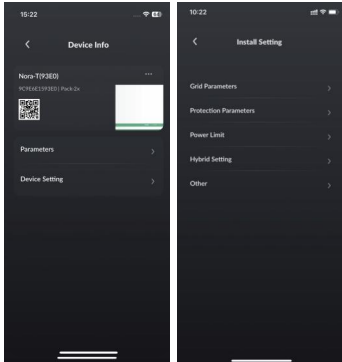

# 1.1.7 Feature Parameters

Tap Console > Feature Parameters to set feature parameters.

Note:

Setting or modifying these parameters requires logging into an administrator account.



## 1.1.8 Power Limit

Tap Console > Power Limit to set the parameters of power limit.

Note:

Setting or modifying these parameters requires logging into an administrator account.

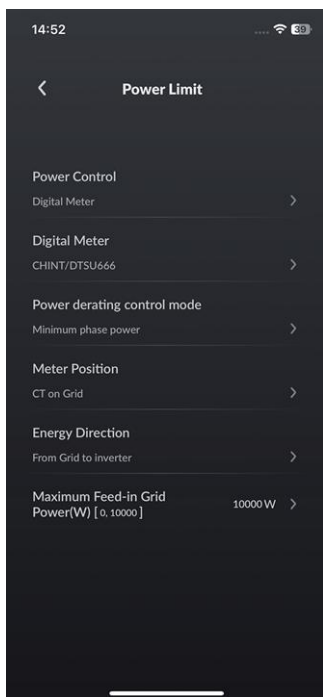

## 1.1.9 Hybrid Setting

Tap Console > Hybrid Setting , view battery information and configure relevant parameters. Enter corresponding information if necessary.

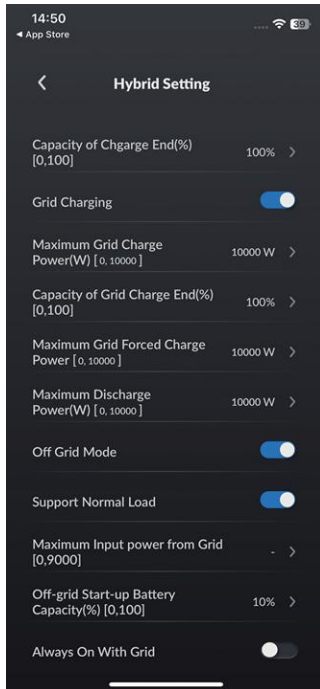

## 1.1.10 User

In User page, you can manage your account.

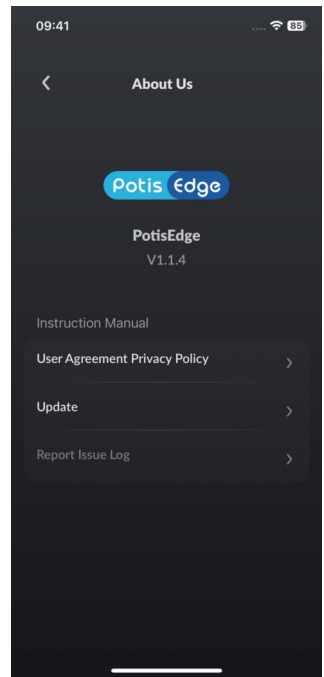
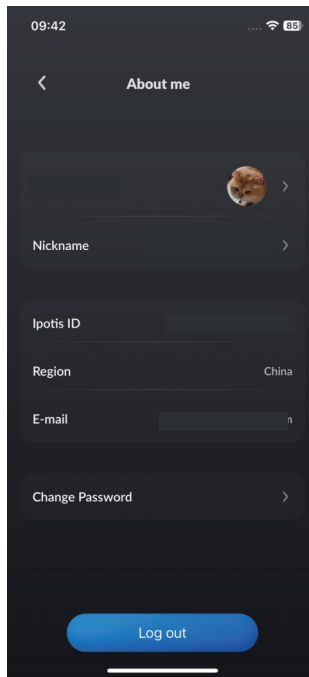
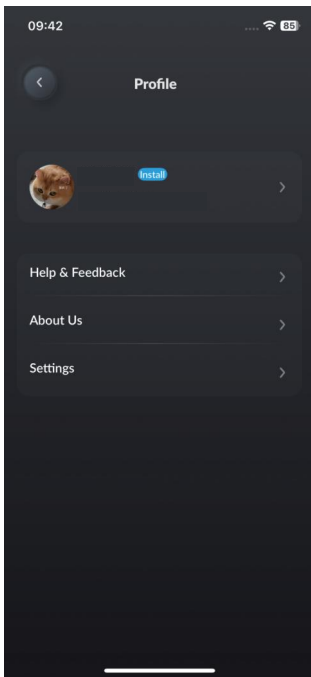

## 1.1.1 Maintenance

In this page,you can do some maintaining operations like turn off/on the inverter and manage data.  
In other page,click Maintenance.

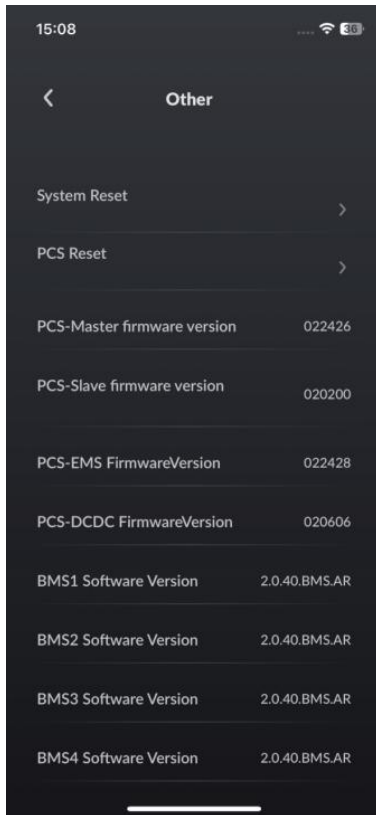

## 1.1.12 Generation and Export Limits

The generation control function is used to control the active or apparent power output levels of an inverter or multiple inverter combination such that it meets a predetermined generation output level that may be less than the total rated apparent power of the inverter or multiple inverter combination.

Please set limit values according to actual necessity and relevant local regulation.

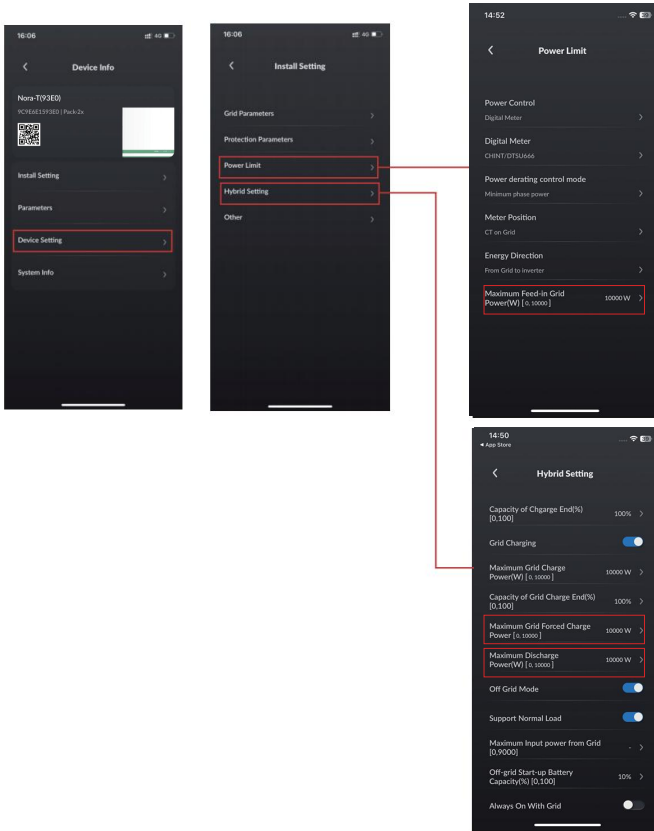

Actual setting contents of the APP may be slightly different, so the screen shots here are only for reference.

### 1.1.13 Install settings

After installer successfully connected to the device, you will see the topology of the system

Step 1: Click [Device Icon] in the topology, then click [Install Setting] to enter install setting page

Step 2: Click [Grid Parameters] and [Others] to check the information about basic setting (including inverter firmware version, standard code, and grid protection settings).

Step 3: Set standard code by entering [Standard Code] page

Step 4: Set the feed-in grid power limit by entering [Power Limit] page

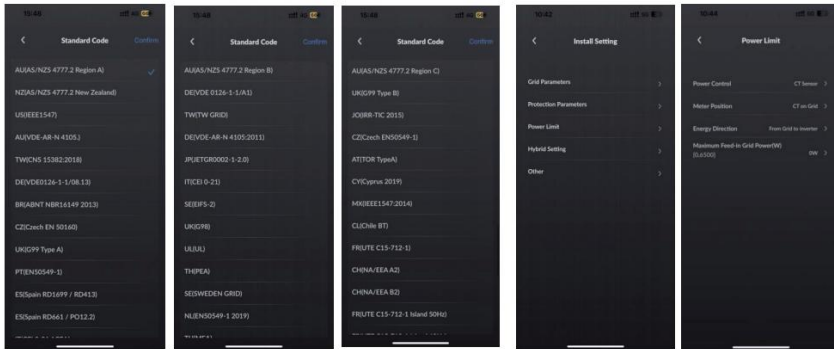
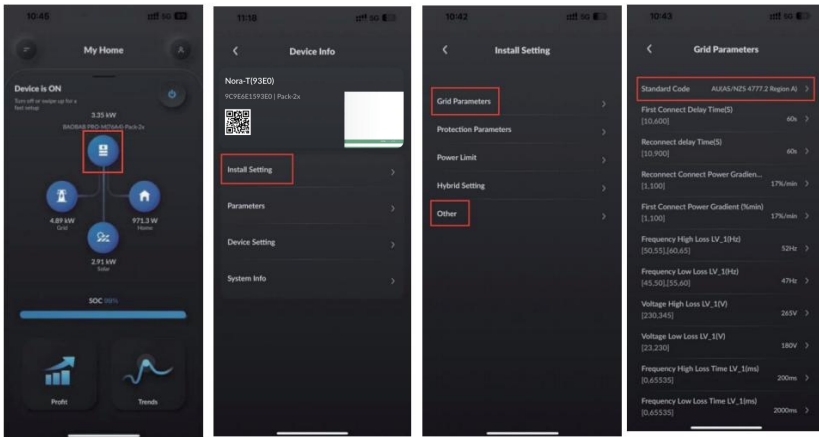

### 1.1.14 Fault inquiry

Step1, Click to report an error fault

Step2, View error codes

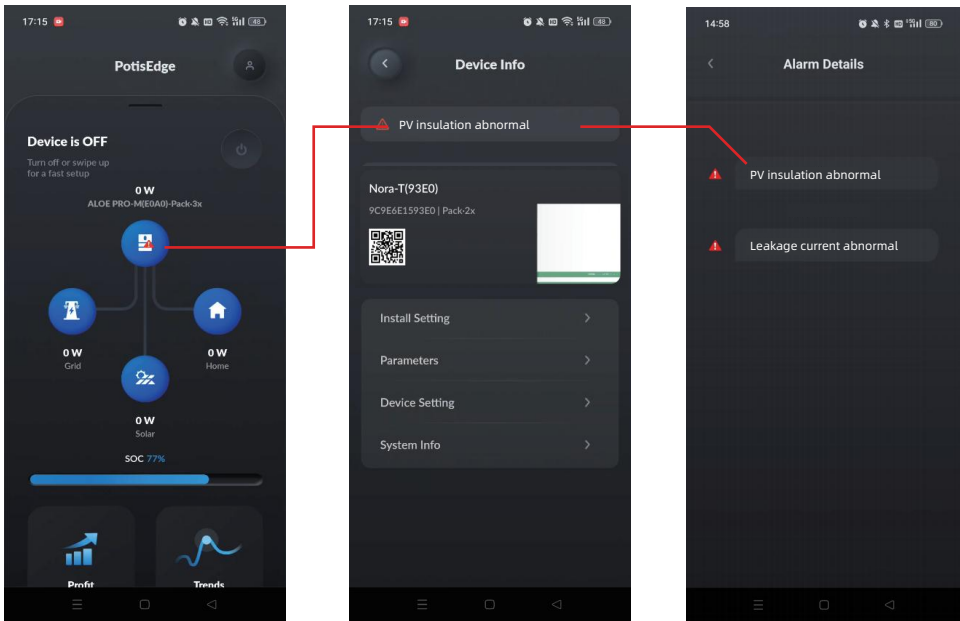

### 1.1.15 Insulation abnormal (Earth fault alarms)

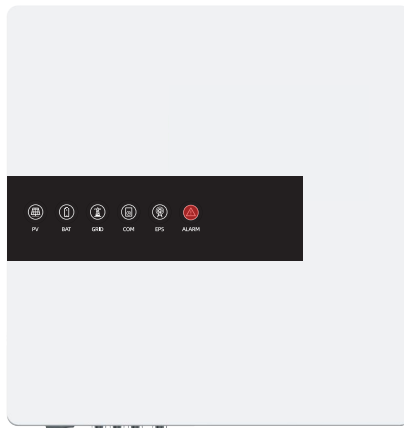
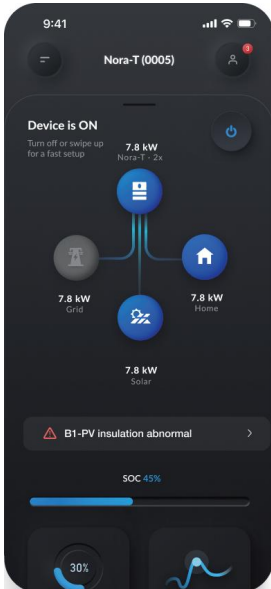

When there is a ground fault alarm, the alarm light on the display board flashes red, and the APP displays a warning message with the words PV insulation abnormal

## 8. Maintenance

### Warning

Before maintaining and commissioning the inverter and its peripheral distribution unit, switch off all the charged terminals of the inverter and wait at least 10 minutes after the inverter is powered off.

### 8.1 Routine Maintenance

Items	Check Content	Maintain Content	Maintenance Interval
Inverter output status	Statistically maintain the status of electrical yield, and remotely monitor its abnormal status.	N/A	Weekly
Inverter cleaning	Check periodically that the heat sink is free from dust and blockage.	Clean periodically the heat sink.	Yearly
Inverter running status	Check that the inverter is not damaged or deformed. Check for normal sound emitted during inverter operation. Check and ensure that all inverter communications is running well.	If there is any abnormal phenomenon, replace the relevant parts.	Monthly
Inverter electrical connections	Check that all AC, DC and communication cables are securely connected; Check that PGND cables are securely connected; Check that all cables are intact and free from aging.	If there is any abnormal phenomenon, replace the cable or re-connect it.	Semiannually

## 8.2 Inverter Troubleshooting

When the inverter has faults, its basic common warning and exception handling methods are shown below.

Code	Alarm Information	Suggestions
A0	Grid over voltage	<ol style="list-style-type: none"> <li>1. If the alarm occurs occasionally, possibly the power grid voltage is abnormal for a short time, and no action is required.</li> <li>2. If the alarm occurs repeatedly, contact the local power station. After receiving approval of the local power bureau, revise the electrical protection parameters settings on the inverter through the App.</li> <li>3. If the alarm persists for along time, check whether the AC circuit breaker /AC terminals is disconnected or not, or if the grid has a power outage.</li> </ol>
A1	Grid under voltage	
A3	Grid over frequency	
A4	Grid under frequency	
A2	Grid absent	Wait till power is restored.
B0	PV over voltage	Check whether the maximum voltage of a single string of input PV mod is greater than the allowable voltage. If the maximum voltage is higher than the standard voltage, modify the number of pv module connection strings.
B1	PV insulation abnormal	<ol style="list-style-type: none"> <li>1. Check the insulation resistance against the ground for the PV strings. If a short circuit has occurred, rectify the fault.</li> <li>2. If the insulation resistance against the ground is less than the default value in a rainy environment, set insulation resistance protection on the App.</li> </ol>
B2	Leakage current abnormal	<ol style="list-style-type: none"> <li>1. If the alarm occurs occasionally, the inverter can be automatically recovered to the normal operating status after the fault is rectified.</li> <li>2. If the alarm occurs repeatedly, contact your dealer for technical support.</li> </ol>
B4	PV under voltage	<ol style="list-style-type: none"> <li>1. If the alarm occurs occasionally, possibly the external circuits are abnormal accidentally. The inverter automatically recovers to the normal operating status after the fault is rectified.</li> <li>2. If the alarm occurs repeatedly or last a long time, check whether the insulation resistance against the ground of PV strings is too low.</li> </ol>
C0	Internal power supply abnormal	<ol style="list-style-type: none"> <li>1. If the alarm occurs occasionally, the inverter can be automatically restored, no action required.</li> <li>2. If the alarm occurs repeatedly, pls. contact the customer service center.</li> </ol>

C2	Inverter over dc-bias current	<ol style="list-style-type: none"> <li>1. If the alarm occurs occasionally, possibly the power grid voltage is abnormal for a short time, and no action is required.</li> <li>2. If the alarm occurs repeatedly, and the inverter fails to generate power, contact the customer service center.</li> </ol>
C3	Inverter relay abnormal	<ol style="list-style-type: none"> <li>1. If the alarm occurs occasionally, possibly the power grid voltage is abnormal for a short time, and no action is required.</li> <li>2. If the alarm occurs repeatedly, pls. refer to the suggestions or measures of Grid over voltage. and the inverter fails to generate power, contact the customer service center. If there is no abnormality on the grid side, the machine fault can be determined. (If you open the cover and find traces of damage to the relay, it can be concluded that the machine is faulty.) And pls. contact the customer service center.</li> </ol>
CN	Remote off	<ol style="list-style-type: none"> <li>1. Local manual shutdown is performed in APP.</li> <li>2. The monitor executed the remote shutdown instruction.</li> <li>3. Remove the communication module and confirm whether the alarm disappears. If it does, replace the communication module. Otherwise, please contact the customer service center.</li> </ol>
C5	Inverter over temperature	<ol style="list-style-type: none"> <li>1. If the alarm occurs occasionally, the inverter can be automatically restored, no action required.</li> <li>2. If the alarm occurs repeatedly, pls. check the installation site for direct sunlight, good ventilation, and high ambient temperature (Such as installed on the parapet). If the ambient temperature is lower than 45 ° C and the heat dissipation is good, contact the customer service center.</li> </ol>
C6	GFCI abnormal	<ol style="list-style-type: none"> <li>1. If the alarm occurs occasionally, it could have been an occasional exception to the external wiring, the inverter can be automatically recovered, no action required.</li> <li>2. If it occurs repeatedly or cannot be recovered for a long time, pls. contact customer service to report repair.</li> </ol>
B7	PV string reverse	Check and modify the positive and negative polarity of the input of the circuit string.
C8	Fan abnormal	<ol style="list-style-type: none"> <li>1. If the alarm occurs occasionally, pls. restart the inverter.</li> <li>2. If it occurs repeatedly or cannot be recovered for a long time, check whether the external fan is blocked by foreign objects. Otherwise, contact customer service.</li> </ol>
C9	Unbalance Dc-link voltage	<ol style="list-style-type: none"> <li>1. If the alarm occurs occasionally, the inverter can be automatically recovered and no action is required.</li> <li>2. If the alarm occurs repeatedly, the inverter cannot work properly. Pls. contact the customer service center.</li> </ol>
CA	Dc-link over voltage	<ol style="list-style-type: none"> <li>2. If the alarm occurs repeatedly, the inverter cannot work properly. Pls. contact the customer service center.</li> </ol>

CB	Internal communication error	<ol style="list-style-type: none"> <li>1. If the alarm occurs occasionally, the inverter can be automatically recovered and no action is required.</li> <li>2. If the alarm occurs repeatedly, the inverter cannot work properly. Pls. contact the customer service center.</li> </ol>
CC	Software incompatibility	<ol style="list-style-type: none"> <li>1. If the alarm occurs occasionally, the inverter can be automatically recovered and no action is required.</li> <li>2. If the alarm occurs repeatedly, the inverter cannot work properly. Pls. contact the customer service center.</li> </ol>
CD	Internal storage error	<ol style="list-style-type: none"> <li>1. If the alarm occurs occasionally, the inverter can be automatically recovered and no action is required.</li> <li>2. If the alarm occurs repeatedly, the inverter cannot work properly. Pls. contact the customer service center.</li> </ol>
CE	Data inconsistency	<ol style="list-style-type: none"> <li>1. If the alarm occurs occasionally, the inverter can be automatically recovered and no action is required.</li> <li>2. If the alarm occurs repeatedly, the inverter cannot work properly. Pls. contact the customer service center.</li> </ol>
CF	Inverter abnormal	<ol style="list-style-type: none"> <li>1. If the alarm occurs occasionally, the inverter can be automatically recovered and no action is required.</li> <li>2. If the alarm occurs repeatedly, the inverter cannot work properly. Pls. contact the customer service center.</li> </ol>
CG	Boost abnormal	<ol style="list-style-type: none"> <li>1. If the alarm occurs occasionally, the inverter can be automatically recovered and no action is required.</li> <li>2. If the alarm occurs repeatedly, the inverter cannot work properly. Pls. contact the customer service center.</li> </ol>
CJ	Meter lost	<ol style="list-style-type: none"> <li>1. Check the meter parameter Settings</li> <li>2. Local APP checks that the communication address of the inverter is consistent with that of the electricity meter</li> <li>3. The communication line is connected incorrectly or in bad contact</li> <li>4. electricity meter failure.</li> <li>5. Exclude the above, if the alarm continues to occur, please contact the customer service center.</li> </ol>

D2	Battery over voltage	<ol style="list-style-type: none"> <li>1. If the alarm occurs occasionally, the inverter can be automatically recovered and no action is required.</li> <li>2. Check that the battery overvoltage protection value is improperly set.</li> <li>3. The battery is abnormal.</li> <li>4. If exclude the above, the alarm continues to occur, please contact the customer service center.</li> </ol>
D3	Battery under voltage	<ol style="list-style-type: none"> <li>1. If the alarm occurs occasionally, the inverter can be automatically recovered and no action is required.</li> <li>2. Check the communication line connection between BMS and inverter (lithium battery).</li> <li>3. The battery is empty or the battery voltage is lower than the SOC cut-off voltage.</li> <li>4. The battery undervoltage protection value is improperly set.</li> <li>5. The battery is abnormal.</li> <li>6. If exclude the above, the alarm continues to occur, please contact the customer service center.</li> </ol>
D4	Battery discharger over current	<ol style="list-style-type: none"> <li>1. Check whether the battery parameters are correctly set.</li> <li>2. Battery undervoltage.</li> <li>3. Check whether a separate battery is loaded and the discharge current exceeds the battery specifications.</li> <li>4. The battery is abnormal.</li> <li>5. If exclude the above, the alarm continues to occur, please contact the customer service center.</li> </ol>
D5	Battery over temperature	<ol style="list-style-type: none"> <li>1. If the alarm occurs repeatedly, please check whether the installation site is in direct sunlight and whether the ambient temperature is too high (such as in a closed room).</li> </ol>
D6	Battery under temperature	<ol style="list-style-type: none"> <li>2. If the battery is abnormal, replace it with a new one.</li> <li>3. If exclude the above, the alarm continues to occur, please contact the customer service center.</li> </ol>
D7	BACKUP output voltage abnormal	<ol style="list-style-type: none"> <li>1. Check whether the BACKUP voltage and frequency Settings are within specified range.</li> <li>2. Check whether the BACKUP port is overloaded.</li> <li>3. When not connected to the power grid, check whether output is normal.</li> <li>4. If exclude the above, the alarm continues to occur, please contact the customer service center.</li> </ol>
D8	Communication error (Inverter-BMS)	<ol style="list-style-type: none"> <li>1. Check whether the battery is disconnected.</li> <li>2. Check whether the battery is well connected with the inverter.</li> <li>3. Confirm that the battery is compatible with the inverter. It is recommended to use CAN communication.</li> <li>4. Check whether the communication cable or port between the battery and the inverter is faulty.</li> <li>5. If exclude the above, the alarm continues to occur, please contact the customer service center.</li> </ol>

D9	Internal communication loss(E-M)	1. Check whether the communication cables between BACKUP, electricity meter and inverter are well connected and whether the wiring is correct 2. Check whether the communication distance is within the specification range
DA	Internal communication loss(M-D)	3. Disconnect the external communication and restart the electricity meter and inverter. 4. If exclude the above, the alarm continues to occur, please contact the customer service center.
CU	Dcdc abnormal	1. If the alarm occurs occasionally, the inverter can be automatically recovered and no action is required. 2. If the alarm occurs repeatedly, please check: 1) Check whether the MC4 terminal on the PV side is securely connected. 2) Check whether the voltage at the PV side is open circuit, ground to ground, etc. If exclude the above, the alarm continues to occur, please contact the customer service center.
CP	BACKUP over dc-bias voltage	1. If the alarm occurs occasionally, the inverter can be automatically recovered and no action is required. 2. If the alarm occurs repeatedly, the inverter cannot work properly. Pls. contact the customer service center.
DB	BACKUP short circuit	1. Check whether the live line and null line of BACKUP output are short-circuited. 2. If it is confirmed that the output is not short-circuited or an alarm, please contact customer service to report for repair. (After the troubleshooting of alarm problems, BACKUP switch needs to be manually turned on during normal use.)
DC	BACKUP over load	1. Disconnect the BACKUP load and check whether the alarm is cleared 2. If the load is disconnected and the alarm is generated, please contact the customer service. (After the alarm is cleared, the BACKUP switch needs to be manually turned on for normal use.)

## 8.3 Removing the Inverter

### Warning

Before removing DC input connector, double check DC input switch is turned to OFF to avoid inverter damage and personal injury.

Perform the following procedures to remove the inverter:

Step 1. Disconnect all cables from the inverter, including communications cables, DC input power cables, AC output power cables, and PGND cable, as shown below.

#### PV Connectors Removing Detail

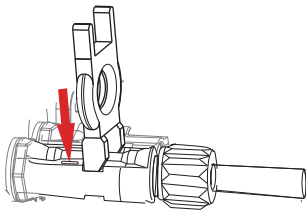

#### NOTE

To remove the PV connectors, insert the removal tool into the bayonet according to the position indicated in the drawing, press inward, and then take out the connector outward.

#### GRID/BACKUP Connectors Removing Detail

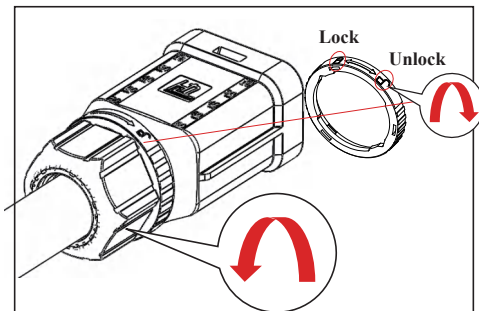
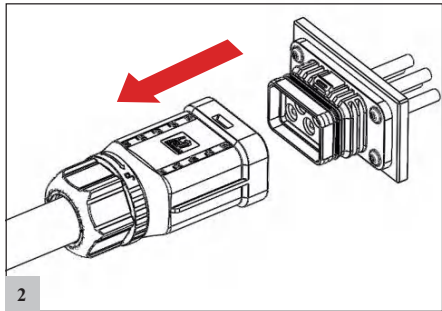
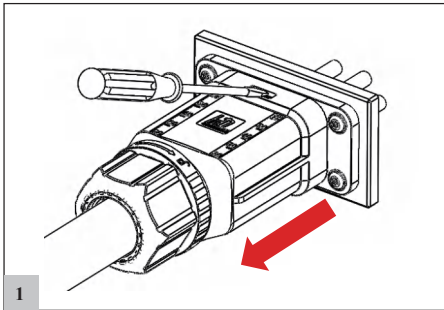

Hold the unlocking button with one hand and turn the nut in the Unlock direction with the other hand.

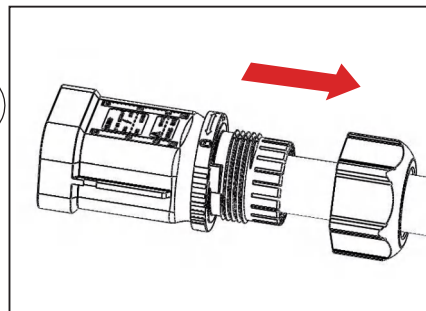

Remove the nut.

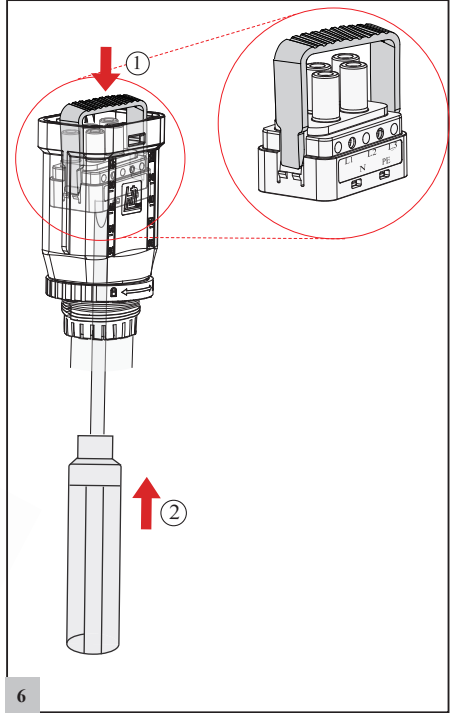
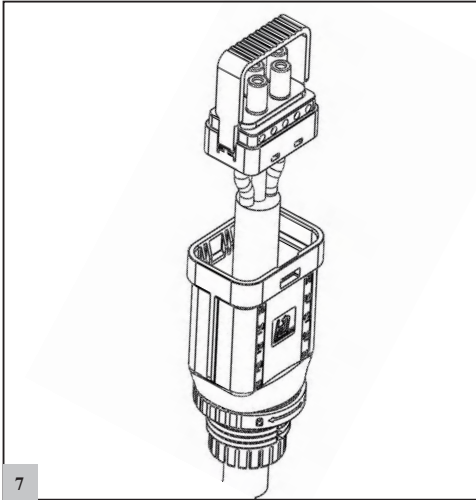
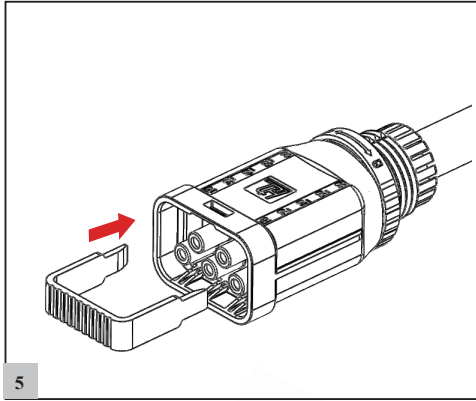

Step 2. Remove the inverter from the mounting bracket.  
Step 3. Remove the mounting bracket.

## 9. Technical Specification

Model	IPT-5K-SH	IPT-6K-SH	IPT-8K-SH	IPT-10K-SH
Model	IPT-5K-S	IPT-6K-S	IPT-8K-S	IPT-10K-S
<b>Input (PV)</b>				
Max. Input Voltage	1000V			
MPPT Operating Voltage Range	160-950V			
Max. Input Power	9000W	9000W	15000W	15000W
Max. Input Current	15A/15A	15A/15A	20A/30A	20A/30A
Max. Short Circuit Current	20A/20A	20A/20A	30A/40A	30A/40A
Max. Number of PV Strings	2(1/1)		3(1/2)	
No. of MPPTs	2			
<b>Input (Battery)</b>				
Compatible battery type	Lithium -ion/Lead-acid			
Battery voltage range	150-600V			
Nominal battery voltage (Full load)	250-600V			
Max. charge/discharge current	25A/25A	25A/25A	50A/50A	50A/50A
Max. charge/discharge power	9000W/5800W	9000W/7000W	15000W/9100W	15000W/11300W
Lithium battery charge curve	Self-adaption to BMS			
<b>Output (On Grid)</b>				
Rated Grid voltage	380V/400V/415V 3W+N+PE			
Rated Grid Frequency	50Hz/60Hz			
Grid Frequency Range**	45Hz -55Hz/55Hz -65Hz			
Nom. Power (Output)	5000W	6000W	8000W	10000W
Maximum Power (Output)	5500W	6600W	8800W	11000W
Apparent Power (Output)	5500VA	6600VA	8800VA	11000VA
Maximum Current (Output)	3*8.3A	3*10A	3*13.3A	3*16.7A/3*16A <sup>①</sup>
Maximum Current (Input)	3*25A	3*25A	3*25A	3*25A
T HDI	< 5%(according to different on-Grid regulation)			
DC Current Injection	<0.5%In			
Power Factor	> 0.99 Rated power (Adjustable 0.8 Leading - 0.8Lagging)			
<b>Output (Backup)</b>				
Nom. power	5000VA	6000VA	8000VA	10000VA
Maximum power(5min)	6000VA	7200VA	9600VA	12000VA
Maximum power(10s)	7500VA	9000VA	12000VA	15000VA
Rated voltage	380V/400V/415V 3W+N+PE			
Backup switch time	10ms(typical), 20ms(max)			
THDV	<3% (R Load) ,8% (RCD Load)			
<b>Efficiency</b>				
Max. Efficiency (PV to Grid)*	98.2%	98.2%	98.4%	98.4%
European Efficiency (PV to Grid)*	97.2%	97.2%	97.9%	97.9%
Max. Charge Efficiency (PV to Battery)*	98%	98%	98%	98%
Max. Charge/Discharge Efficiency (Grid to Battery)*	98%	98%	98%	98%

①: The specification of “3\*16A” is only for British Market.

Protection	
DC switch	Support
Anti -islanding protection	Support
AC overcurrent protection	Support
AC short circuit protection	Support
AC over -voltage protection	Support
SPD	DC Type2, AC Type2
GFCI	Support
AFCI	Optional
RSD	Optional (Tigo/APS)
Insulation detection	Support
General	
Topology	Transformerless
IP Rating	IP65
Cooling	Natural cooling
Operating Temperature Range	-25°C -60°C
Relative Humidity Range	0-100%
Max. Operating Altitude	4000m(>2000m derating )
Noise	<30 dB(Measured at 1m)
Dimensions (W*H*D)	530*550*213mm(IPT-xK-S) 530*550*232mm(IPT-xK-SH)
Weight	29.6KG 32KG
Pollution degree classification	PD3
Voltage Class DVC	Class A(DC), Class C(PV), Class C(AC), Class A(COM)
HMI & COM	
Display	APP +LED
Communication	WiFi/GPRS/4G/Ethernet(optional);
	BMS(CAN/RS485)
	DRM
	1*DI
	2*DO
	METER(RS485) RS485
Certification	
Safety	IEC 62109-1/2
EMC	EN IEC 61000-6-1:2019,EN IEC 61000-6-2:2019,EN IEC 61000-6-3:20216,
	EN IEC 61000-6-4:2019,IEC 61000-3-2:2018,IEC 61000-3-3:2013+A1,
Grid Code	VDE-AR-N 4105:2018, DIN VDE V 0124-100(VDE V 0124-100):2020,
	RfG:2016, NC RfG:2018, PTPiREE:2021
Warranty	5 Years/10 Years (Optional)
Pollution degree classification	PD3
Voltage Class DVC	Class A(DC), Class C(PV), Class C(AC), Class A(COM)
Production	China

Remarks :

- \*Not yet tested;
- \*\*The range of output voltage and frequency may vary depending upon different grid codes.
- Specifications are subject to change without advance notice.
- The energy storage system will reduce the output under high temperature ( above 45 °C) for self-protection.

# ANNEX 01 Schematic Diagram

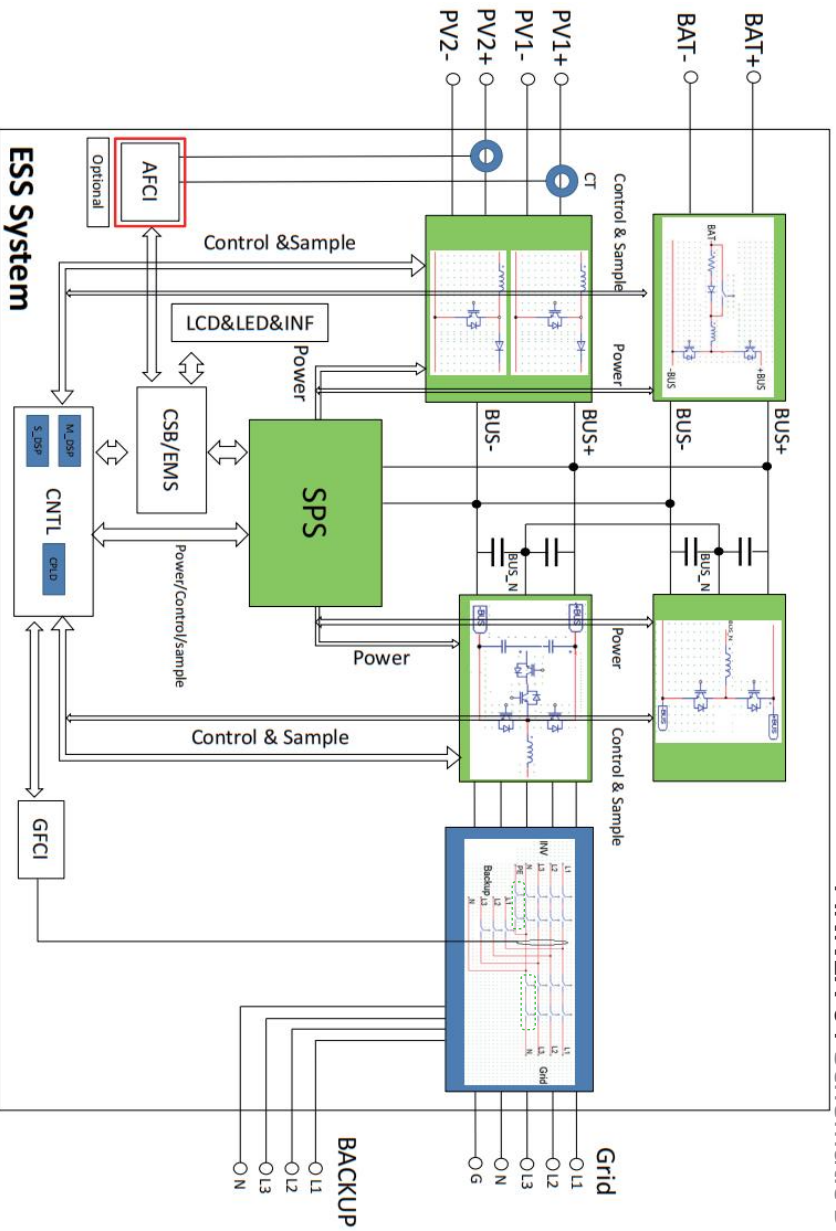

- 01, Grid-connected and standby mode switching via relay.
- 02, In inverters, the N-PE relay is normally closed (conducting) during regular operation (Note: Australian market block this function).
- 03, In operating backup mode, neutral continuity is maintained internal to the inverter.



© 2023 iPotisEdge Co., Ltd. All rights reserved.

JK Energy and iPotisEdge are trademarks of iPotisEdge Co., Ltd.  
All other trademarks are owned by iPotisEdge Co., Ltd or their respective owners.

For more information about iPotisEdge ESS Solutions please visit: [ipotisedge.com](https://ipotisedge.com)

Write us an e-mail: [sales@ipotisedge.com](mailto:sales@ipotisedge.com)

Or follow us:     